

SPARE PARTS

---

# SEMI-AUTOMATIC DIVIDERS

---

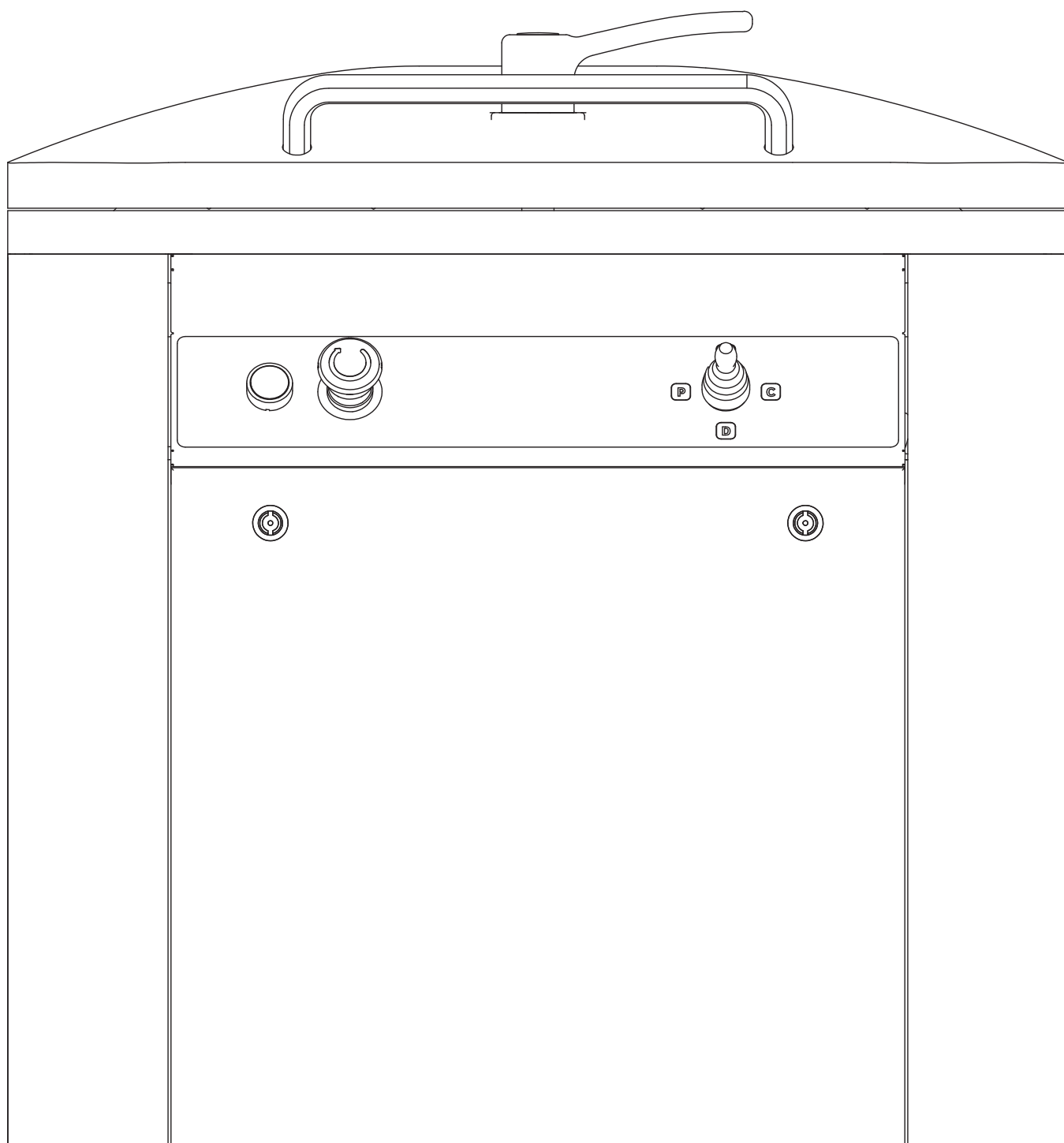



- 4** COVER GROUP
- 5** COVER LID
- 6** COVER BALANCING
- 7** FRAME
- 8** STANDARD CASING
- 9** 4 REMOVABLE PANNELS CASING
- 10** RECTANGULAR BASIN GROUP
  - 11** 10 DIVISIONS KNIFE GROUP
  - 12** 20 DIVISIONS KNIFE GROUP
  - 13** 24 DIVISIONS KNIFE GROUP
  - 14** 30 DIVISIONS KNIFE GROUP
  - 15** 40 DIVISIONS KNIFE GROUP
  - 16** 48 DIVISIONS KNIFE GROUP
  - 17** 60 DIVISIONS KNIFE GROUP
  - 18** 80 DIVISIONS KNIFE GROUP
- 19** DOUBLE CUT HOOKING GROUP
  - 20** 10/20 DIV. KNIFE GROUP
  - 21** 12/24 DIV. KNIFE GROUP
  - 22** 15/30 DIV. KNIFE GROUP
- 24** ROUND BASIN GROUP
  - 25** 16 DIVISIONS KNIFE GROUP
  - 26** 20 DIVISIONS KNIFE GROUP
  - 27** 24 DIVISIONS KNIFE GROUP
- 28** EXAGONAL BASIN 37/57 GROUP
  - 29** 37/57 DIVISIONS KNIFE GROUP
- 30** EXAGONAL BASIN 37/65 GROUP
  - 31** 37/65 DIVISIONS KNIFE GROUP
- 32** EXAGONAL BASIN 85 GROUP
  - 33** 19/85 DIVISIONS KNIFE GROUP
- 34** RECTANGULAR SMALL BASIN GROUP
  - 35** 10s DIVISIONS KNIFE GROUP
  - 36** 20s DIVISIONS KNIFE GROUP
- 38** HYDRAULIC GROUP
- 39** DOUBLE CUT HYDRAULIC GROUP
- 40** ELECTRICAL GROUP
- 41** ELECTRICAL BOX UL/CSA
- 42** ELECTRICAL BOX STANDARD

**COVER GROUP COD. CP000005**

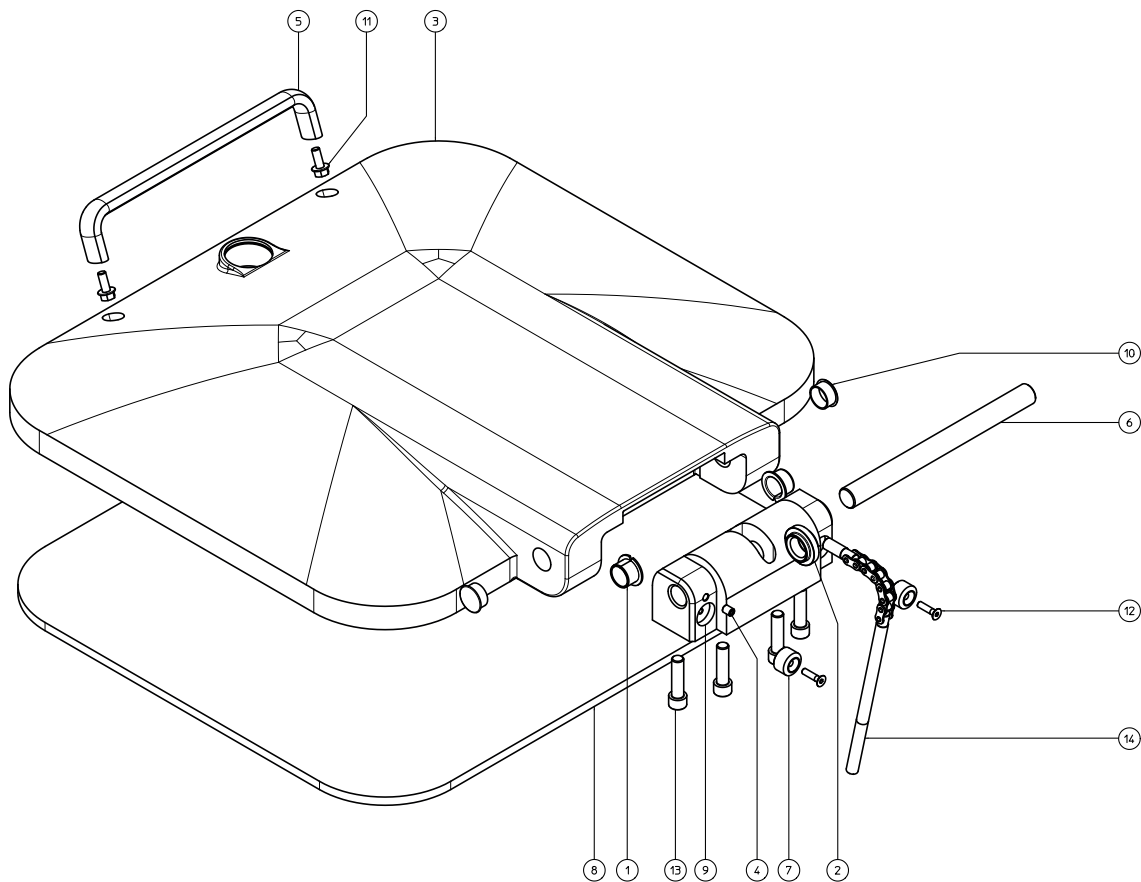

POSITION	QUANTITY	CODE	DESCRIPTION
1	2	18072216	LATCH INSERT KF 22 15
2	1	33800031	CHAIN GUIDE
3	1	35050004	COVER
4	1	37010810	SCREW M8X10
5	1	43712630	HANDLE COVER
6	1	49410030	COVER PIN
7	2	50850029	STOPPER
8	1	50850039	COVER PLATE
9	1	61900041	LID SUPPORT
10	2	64920008	PLUG
11	2	69210820	SCREW M8X20 ZINC.
12	2	69270625	SCREW M6X25 INOX
13	4	69161245	SCREW M12X45 ZINC.
14	1	18100005	BALANCE CHAIN

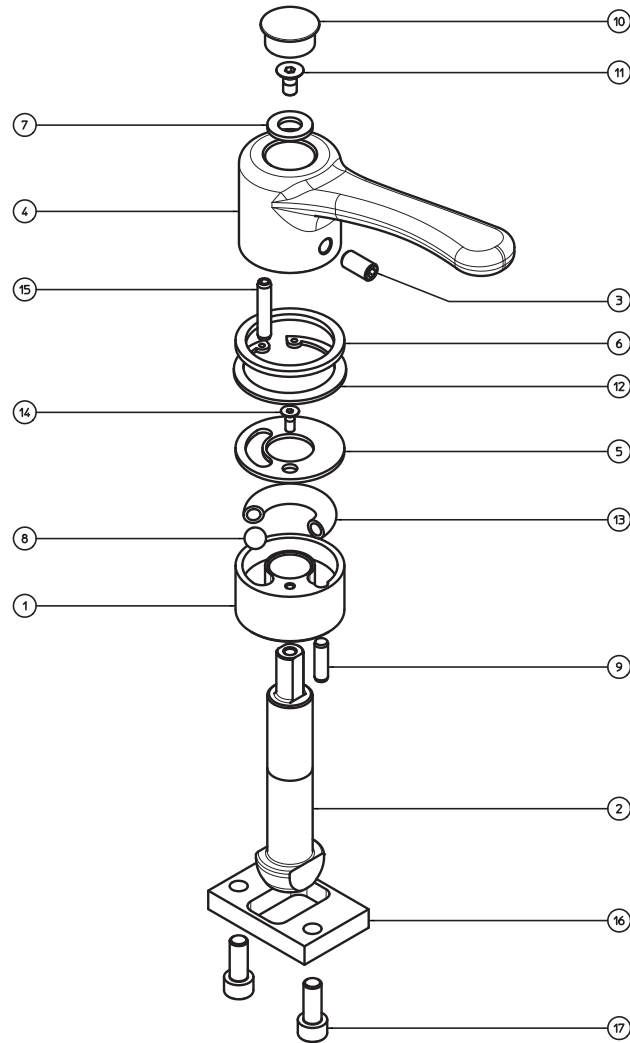

POSITION	QUANTITY	CODE	DESCRIPTION
1	1	17910008	LATCH LID COVER
2	1	35440011	LID COVER
3	1	37040815	SCREW M08X16
4	1	43700006	LID HANDLE
5	1	58910008	WASHER LID COVER
6	1	58920004	WASHER HANDLE COVER
7	1	59151020	WASHER D. 10 ZINC.
8	1	61610002	BALL D. 9,52
9	1	63030620	RECTIFIED PLUG D.6X20
10	1	64920002	PLUG
11	1	69240612	SCREW M6X12 ZINC.
12	1	14120047	SEEGER RING D.47
13	1	44820027	COMPRESSION SPRING C027
14	1	69270410	SCREW M4X10 INOX
15	1	63080630	PLUG D.6X30
16	1	49660018	HOOK CONNECTION
17	2	69160820	SCREW M8X20 ZINC.

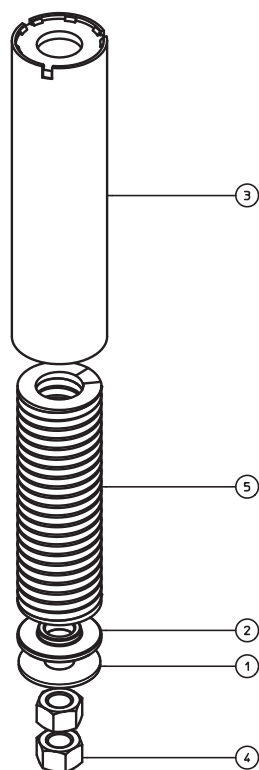

POSITION	QUANTITY	CODE	DESCRIPTION
1	1	59091236	WASHER D12X36 SP. 2 ZINC.
2	1	58920002	LOWER BALANCING WASHER
3	1	66880053	PIPE
4	2	30131201	NUT M12 ZINC.
5	1	44873818	BLU SPRING D38X180

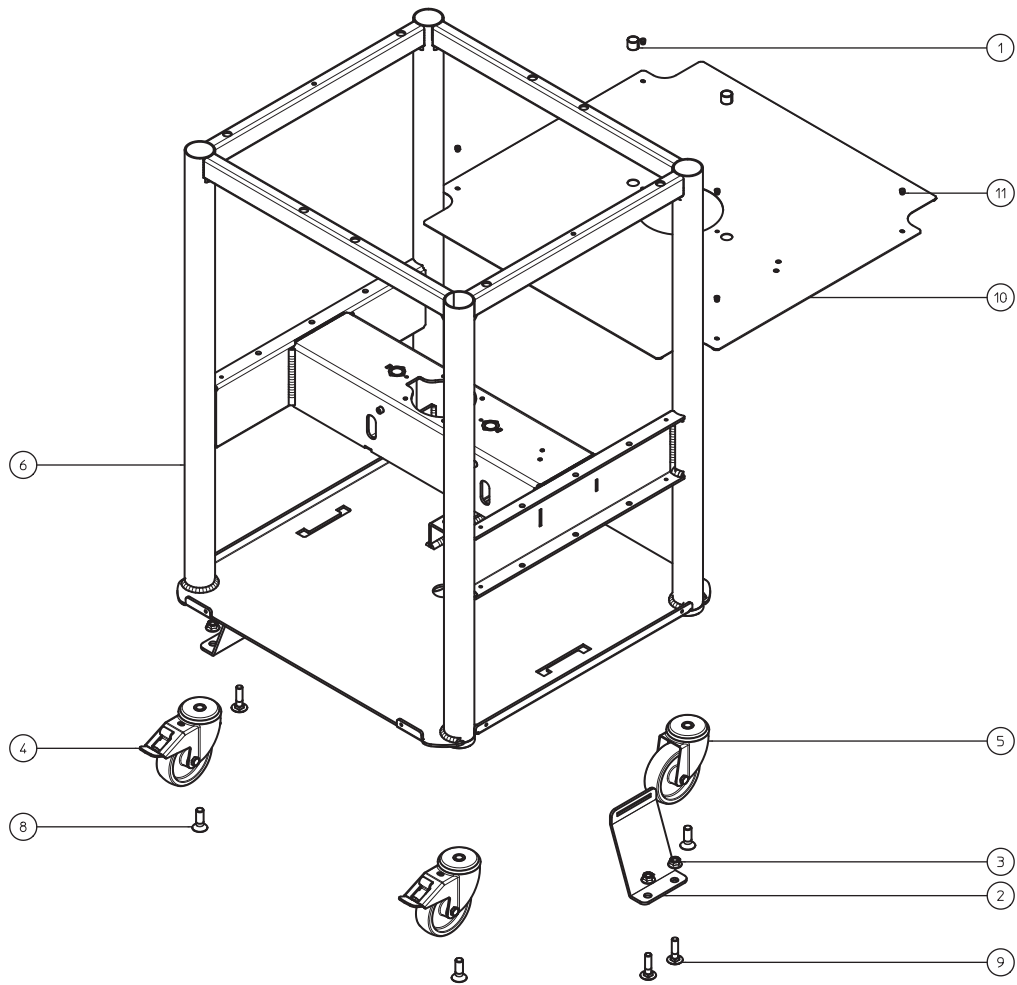

POSITION	QUANTITY	CODE	DESCRIPTION
1	2	18061615	LATCH INSERT KU 1615
2	2	20120281	MOUNTING BRACKET
3	4	30211001	NUT M10 ZINC.
4	2	59860003	CASTER WITH BRAKE
5	2	59860004	CASTER WITHOUT BRAKE
6	1	60010040	FRAME
7	2	69160612	SCREW M6X12 ZINC.
8	4	69241235	SCREW M12X35 ZINC.
9	4	69251040	SCREW M10X40 ZINC.
10	1	20120302	DEBRIS CATCH PLATE
11	6	58250410	ALUMINUM RIVET

**STANDARD CASING COD. CR000003**

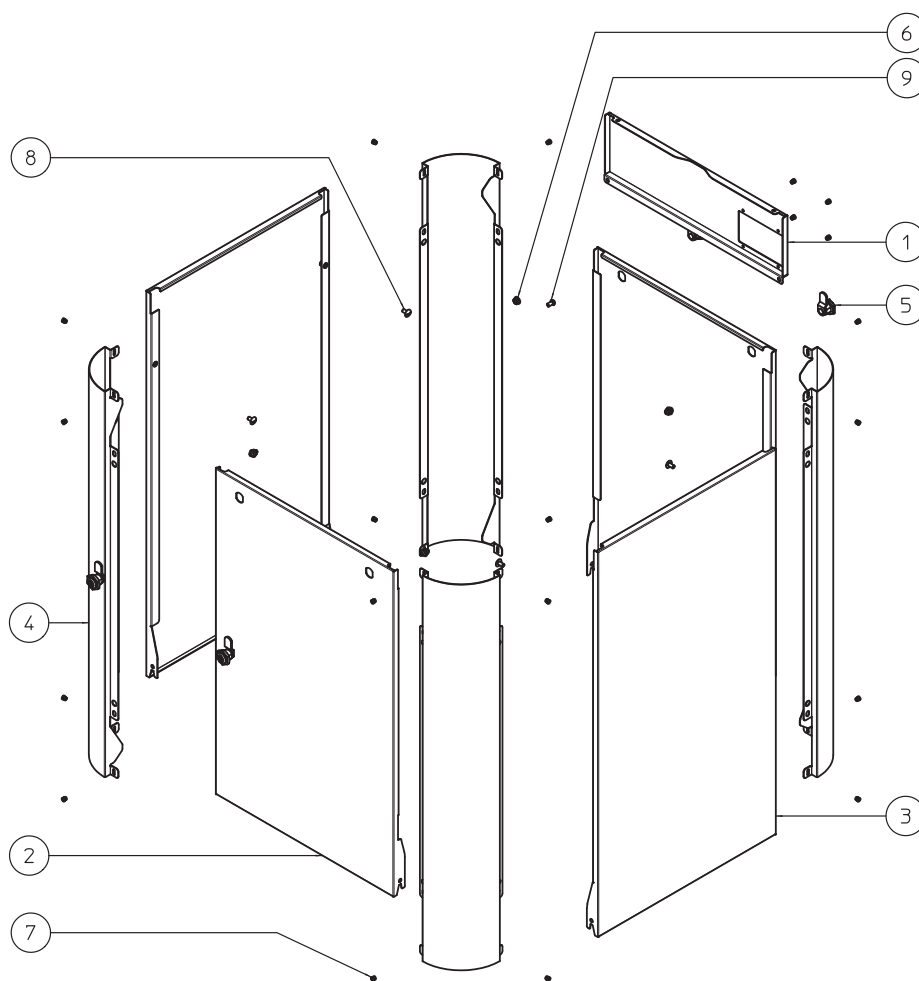

POSITION	QUANTITY	CODE	DESCRIPTION
1	1	20120299	POWER SUPPLY PANNEL
2	2	20120296	REMOVABLE PANNEL
3	2	20120305	LATERAL PANNEL
4	4	20120297	ANGULAR PANNEL
5	4	22803621	LOCK
6	4	30190601	NUT M6 ZINC.
7	20	58250410	ALUMINUM RIVET
8	4	69100612	SCREW M6X12 ZINC.



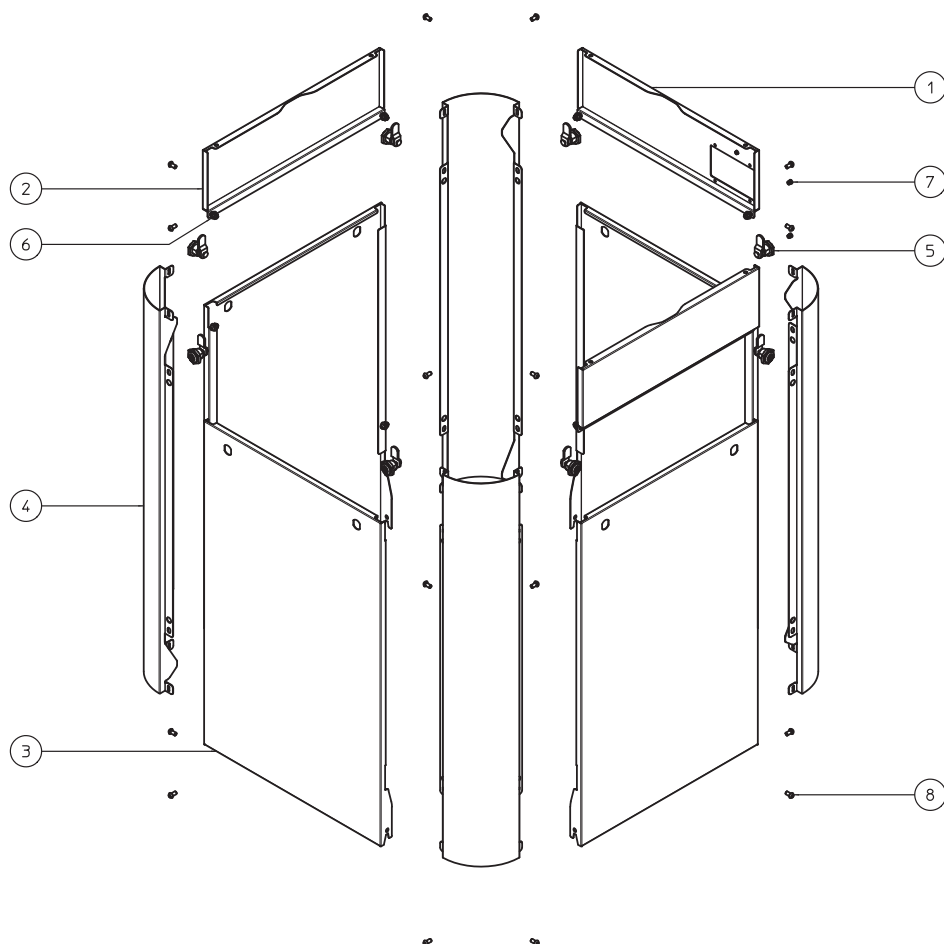

POSITION	QUANTITY	CODE	DESCRIPTION
1	1	20120299	POWER SUPPLY PANNEL
2	2	20120296	FIX LATERAL PANNEL
3	4	20120300	REMOVABLE PANNEL
4	4	20120297	ANGULAR PANNEL
5	8	22803621	LOCK
6	8	30190601	NUT M6 ZINC.
7	20	58250410	ALUMINUM RIVET
8	8	69180612	SCREW M6X12 ZINC.

**RECTANGULAR BASIN GROUP COD. VS000007**

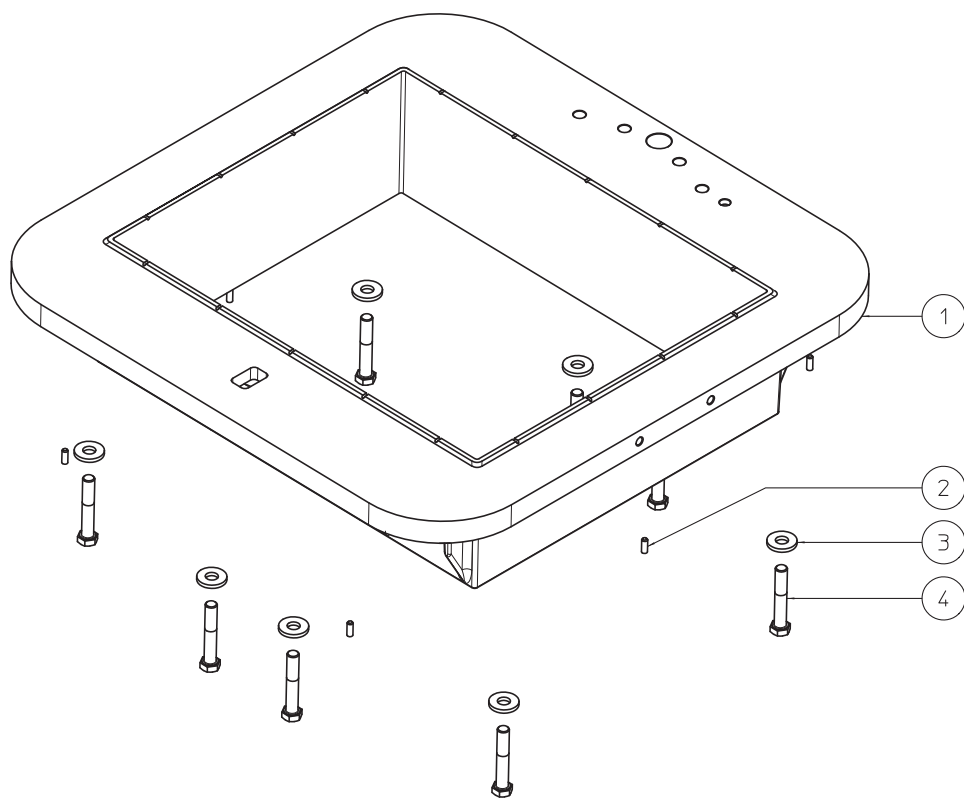

POSITION	QUANTITY	CODE	DESCRIPTION
1	1	35150008	RECTANGULAR BASIN
2	6	37040616	SCREW M06X16
3	8	59091230	WASHER D.12X30 SP. 4 ZINC.
4	8	69201270	SCREW M12X70 ZINC.

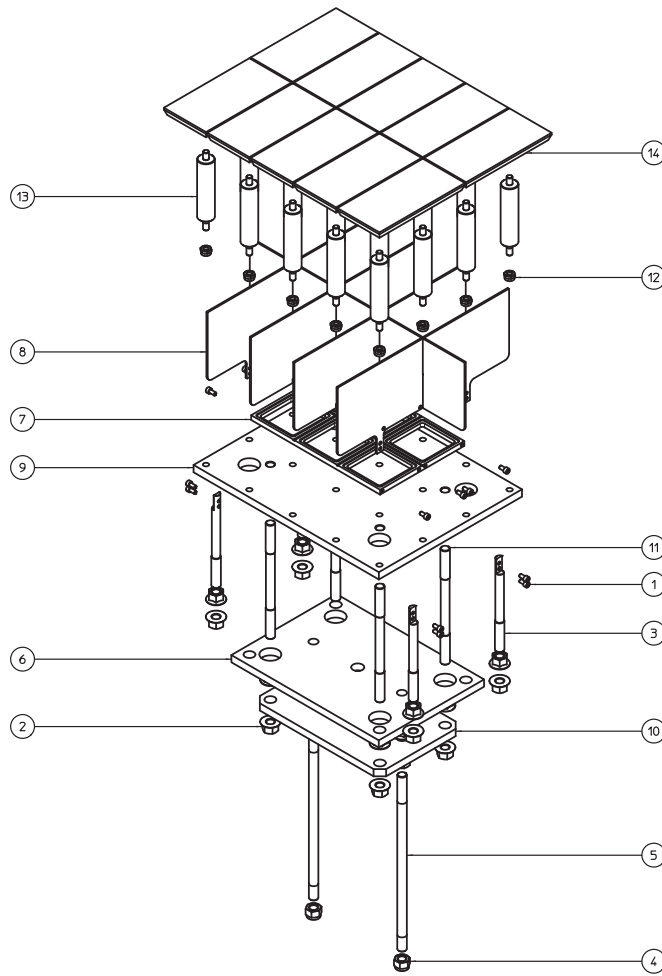

POSITION	QUANTITY	CODE	DESCRIPTION
1	12	69280612	SCREW M6X12 INOX
2	24	30191601	NUT M16 ZINC.
3	4	65810010	CUTTING KNIFE SUPPORT SHAFTS
4	2	30081601	SELFLOCKING NUT M16 ZINC.
5	2	65810012	FIXED LIMIT ROD
6	1	49420111	KNIFE SUPPORT PLATE
7	1	49420130	KNIFE SUPPORT PLATE
8	1	60040148	KNIFE
9	1	49420110	PRESS SUPPORT PLATE
10	1	49420112	PRESS SUPPORT GUIDE ROD PLATE
11	4	65810011	PRESS SUPPORT PLATE GUIDE RODS
12	20	30091001	NUT M10 ZINC.
13	20	62000005	PRESS PLATE SUPPORT
14	10	52600034	PRESS PLATES

20 DIVISIONS KNIFE GROUP **COD. TG000019**

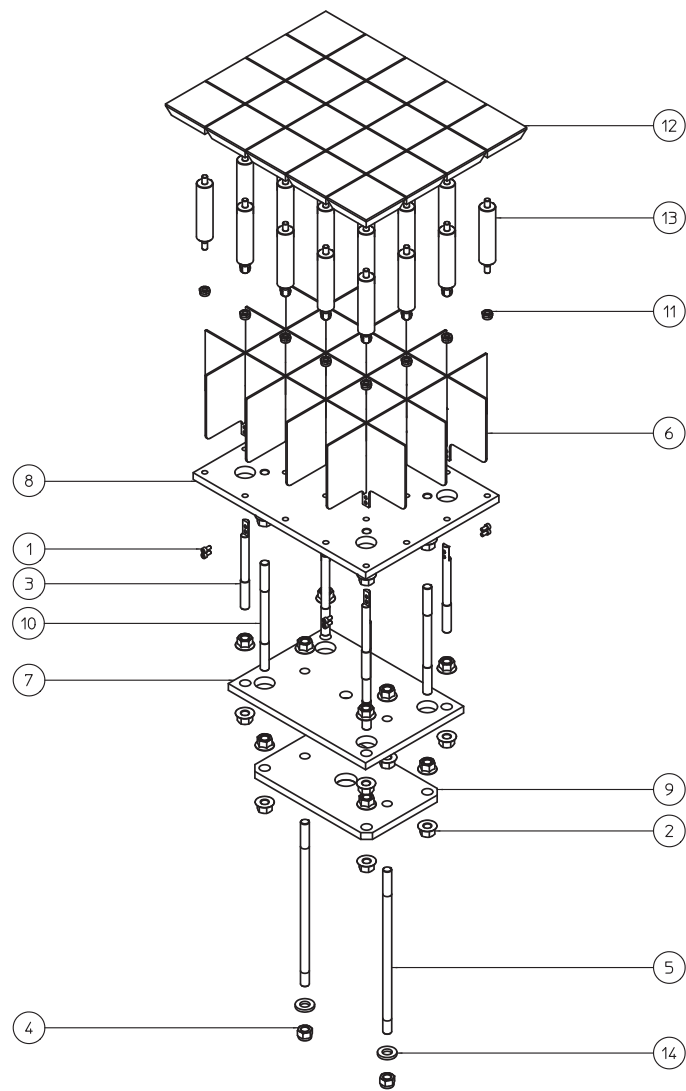

POSITION	QUANTITY	CODE	DESCRIPTION
1	8	69280612	SCREW M6X12 INOX
2	24	30191601	NUT M16 ZINC.
3	4	65810010	CUTTING KNIFE SUPPORT SHAFTS
4	2	30081601	SELFLOCKING NUT M16 ZINC.
5	2	65810012	FIXED LIMIT ROD
6	1	60040140	KNIFE
7	1	49420111	KNIFE SUPPORT PLATE
8	1	49420110	PRESS SUPPORT PLATE
9	1	49420112	PRESS SUPPORT GUIDE ROD PLATE
10	4	65810011	PRESS SUPPORT PLATE GUIDE RODS
11	20	30091001	NUT SELFLOCKING M10 ZINC.
12	20	52600030	PRESS PLATES
13	20	62000005	PRESS PLATE SUPPORT
14	2	59091635	WASHER D.16X35 SP. 5 ZINC.

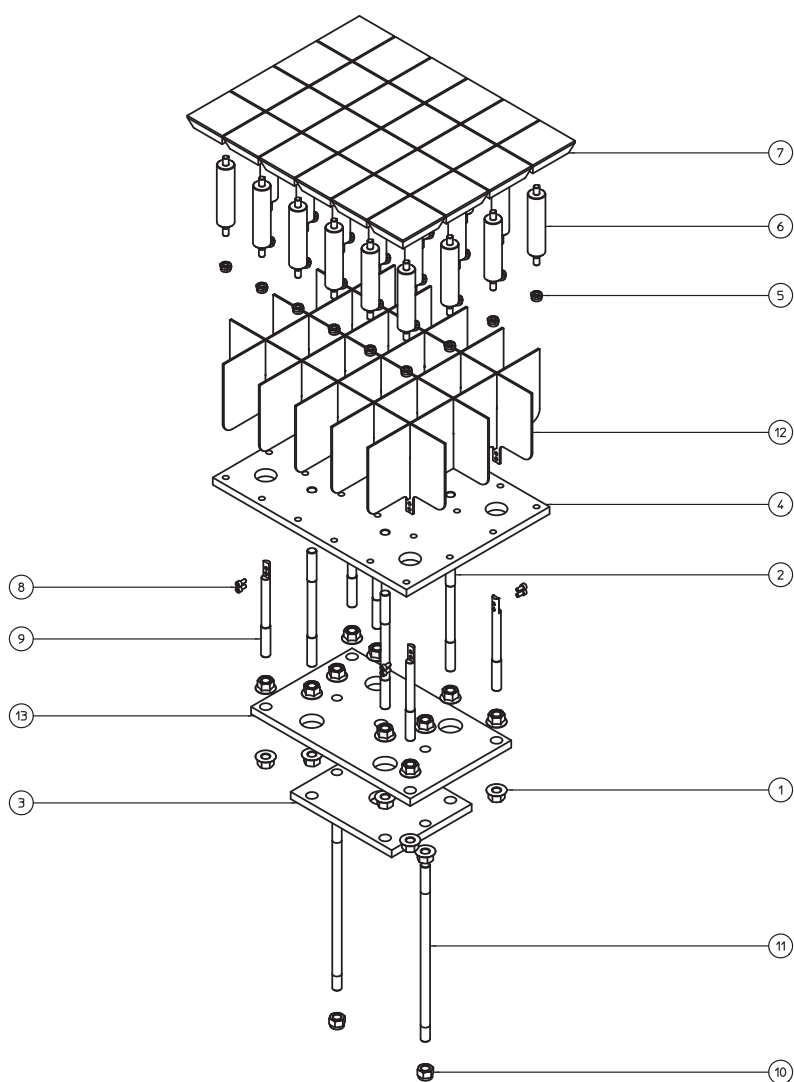

POSITION	QUANTITY	CODE	DESCRIPTION
1	24	30191601	NUT M16 ZINC.
2	4	65810011	PRESS SUPPORT PLATE GUIDE RODS
3	1	49420133	PRESS SUPPORT GUIDE ROD PLATE
4	1	49420134	PRESS SUPPORT PLATE
5	24	30091001	NUT SELFLOCKING M10 ZINC.
6	24	62000005	PRESS PLATE SUPPORT
7	24	52600036	PRESS PLATES
8	8	69280612	SCREW M6X12 INOX
9	4	65810010	CUTTING KNIFE SUPPORT SHAFTS
10	2	30081601	SELFLOCKING NUT M16 ZINC.
11	2	65810012	FIXED LIMIT ROD
12	1	60040149	KNIFE
13	1	49420135	KNIFE SUPPORT PLATE

30 DIVISIONS KNIFE GROUP **COD. TG000024**

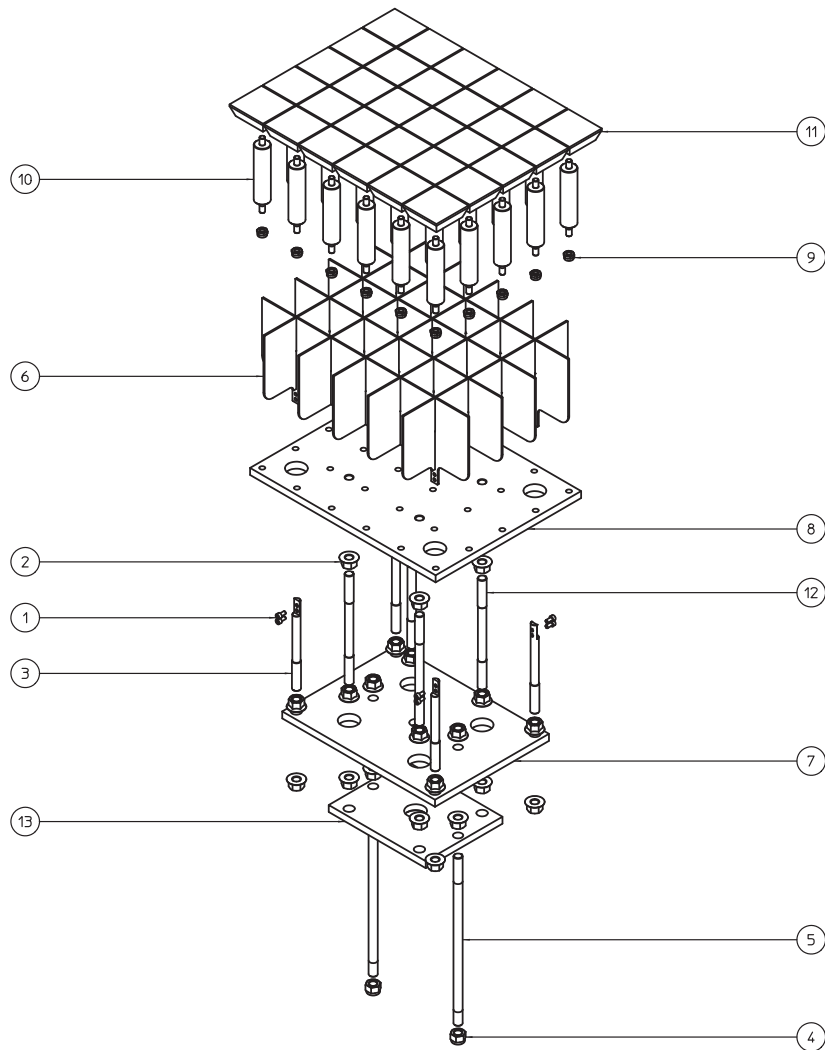

POSITION	QUANTITY	CODE	DESCRIPTION
1	8	69280612	SCREW M6X12 INOX
2	24	30191601	NUT M16 ZINC.
3	4	65810010	CUTTING KNIFE SUPPORT SHAFTS
4	2	30081601	SELFLOCKING NUT M16 ZINC.
5	2	65810012	FIXED LIMIT ROD
6	1	60040147	KNIFE
7	1	49420132	KNIFE SUPPORT PLATE
8	1	49420131	PRESS SUPPORT PLATE
9	30	30091001	NUT SELFLOCKING M10 ZINC.
10	30	62000005	PRESS PLATE SUPPORT
11	30	52600035	PRESS PLATES
12	4	65810011	PRESS SUPPORT PLATE GUIDE RODS
13	1	49420133	PRESS SUPPORT GUIDE ROD PLATE

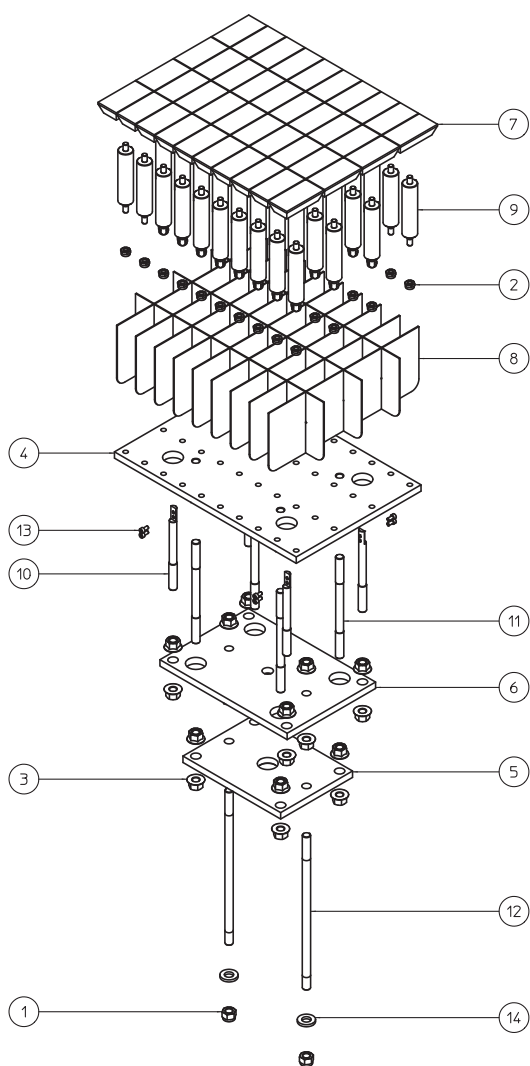

POSITION	QUANTITY	CODE	DESCRIPTION
1	2	30081601	SELFLOCKING NUT M16 ZINC.
2	40	30091001	NUT SELFLOCKING M10 ZINC.
3	24	30191601	NUT M16 ZINC.
4	1	49420153	PRESS SUPPORT PLATE
5	1	49420154	PRESS SUPPORT GUIDE ROD PLATE
6	1	49420155	KNIFE SUPPORT PLATE
7	40	52600041	PRESS PLATES
8	1	60040161	KNIFE
9	40	62000005	PRESS PLATE SUPPORT
10	4	65810010	CUTTING KNIFE SUPPORT SHAFTS
11	4	65810011	PRESS SUPPORT PLATE GUIDE RODS
12	2	65810012	FIXED LIMIT ROD
13	8	69280612	SCREW M6X12 INOX
14	2	59091635	WASHER D.16X35 SP. 5 ZINC.

48 DIVISIONS KNIFE GROUP **COD. TG000043**

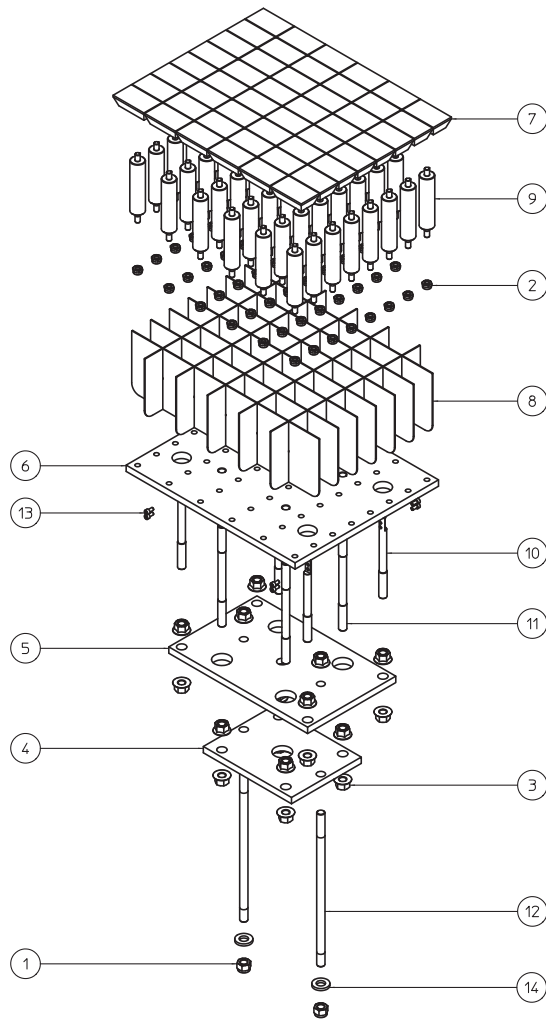

POSITION	QUANTITY	CODE	DESCRIPTION
1	2	30081601	SELFLOCKING NUT M16 ZINC.
2	48	30091001	NUT SELFLOCKING M10 ZINC.
3	24	30191601	NUT M16 ZINC.
4	1	49420133	PRESS SUPPORT GUIDE ROD PLATE
5	1	49420135	KNIFE SUPPORT PLATE
6	1	49420164	PRESS SUPPORT PLATE
7	48	52600045	PRESS PLATES
8	1	60040170	KNIFE
9	48	62000005	PRESS PLATE SUPPORT
10	4	65810010	CUTTING KNIFE SUPPORT SHAFTS
11	4	65810011	PRESS SUPPORT PLATE GUIDE RODS
12	2	65810012	FIXED LIMIT ROD
13	8	69280612	SCREW M6X12 INOX
14	2	59091635	WASHER D.16X35 SP. 5 ZINC.



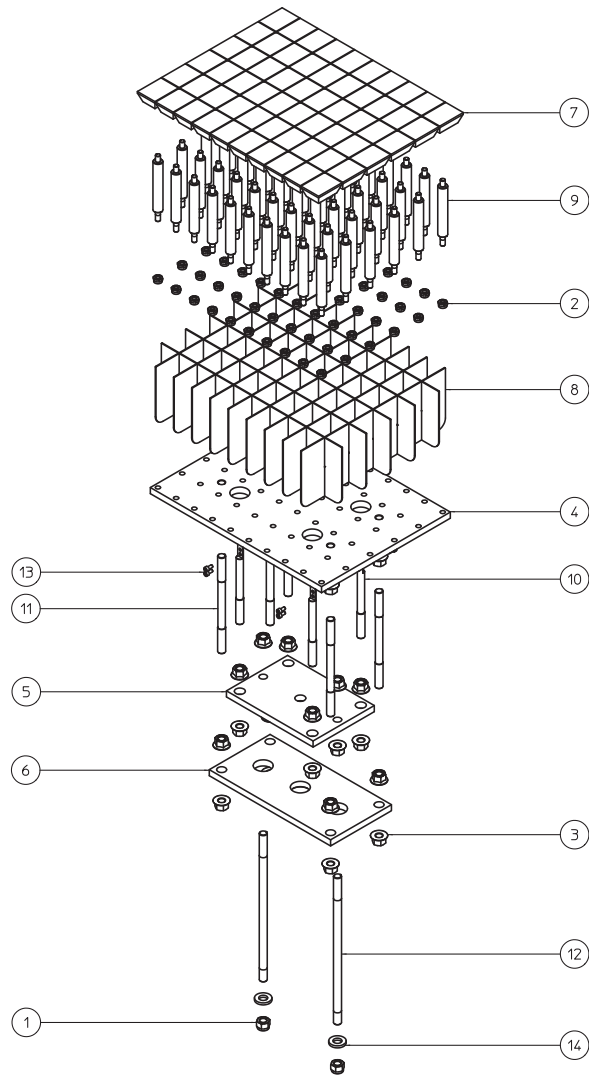

POSITION	QUANTITY	CODE	DESCRIPTION
1	2	30081601	SELFLOCKING NUT M16 ZINC.
2	60	30091001	NUT SELFLOCKING M10 ZINC.
3	24	30191601	NUT M16 ZINC.
4	1	49420105	PRESS SUPPORT PLATE
5	1	49420106	KNIFE SUPPORT PLATE
6	1	49420107	PRESS SUPPORT GUIDE ROD PLATE
7	60	52600042	PRESS PLATES
8	1	60040162	KNIFE
9	60	62000006	PRESS PLATE SUPPORT
10	4	65810010	CUTTING KNIFE SUPPORT SHAFTS
11	4	65810011	PRESS SUPPORT PLATE GUIDE RODS
12	2	65810012	FIXED LIMIT ROD
13	8	69280612	SCREW M6X12 INOX
14	2	59091635	WASHER D.16X35 SP. 5 ZINC.

80 DIVISIONS KNIFE GROUP **COD. TG000040**

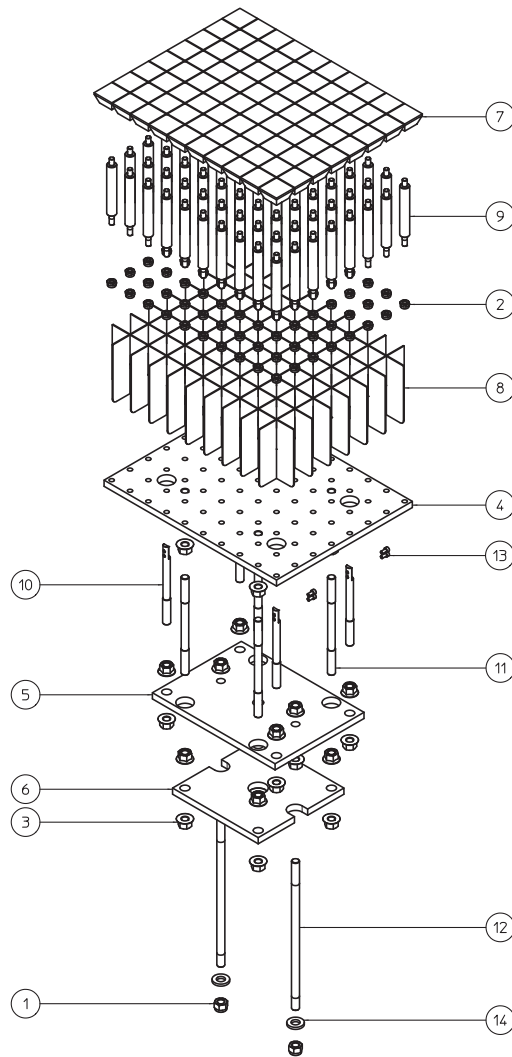

POSITION	QUANTITY	CODE	DESCRIPTION
1	2	30081601	SELFLOCKING NUT M16 ZINC.
2	80	30091001	NUT SELFLOCKING M10 ZINC.
3	24	30191601	NUT M16 ZINC.
4	1	49420008	PRESS SUPPORT PLATE
5	1	49420014	KNIFE SUPPORT PLATE
6	1	49420019	PRESS SUPPORT GUIDE ROD PLATE
7	80	52600005	PRESS PLATES
8	1	60040167	KNIFE
9	80	62000006	PRESS PLATE SUPPORT
10	4	65810010	CUTTING KNIFE SUPPORT SHAFTS
11	4	65810011	PRESS SUPPORT PLATE GUIDE RODS
12	2	65810012	FIXED LIMIT ROD
13	8	69280612	SCREW M6X12 INOX
14	2	59091635	WASHER D.16X35 SP. 5 ZINC.

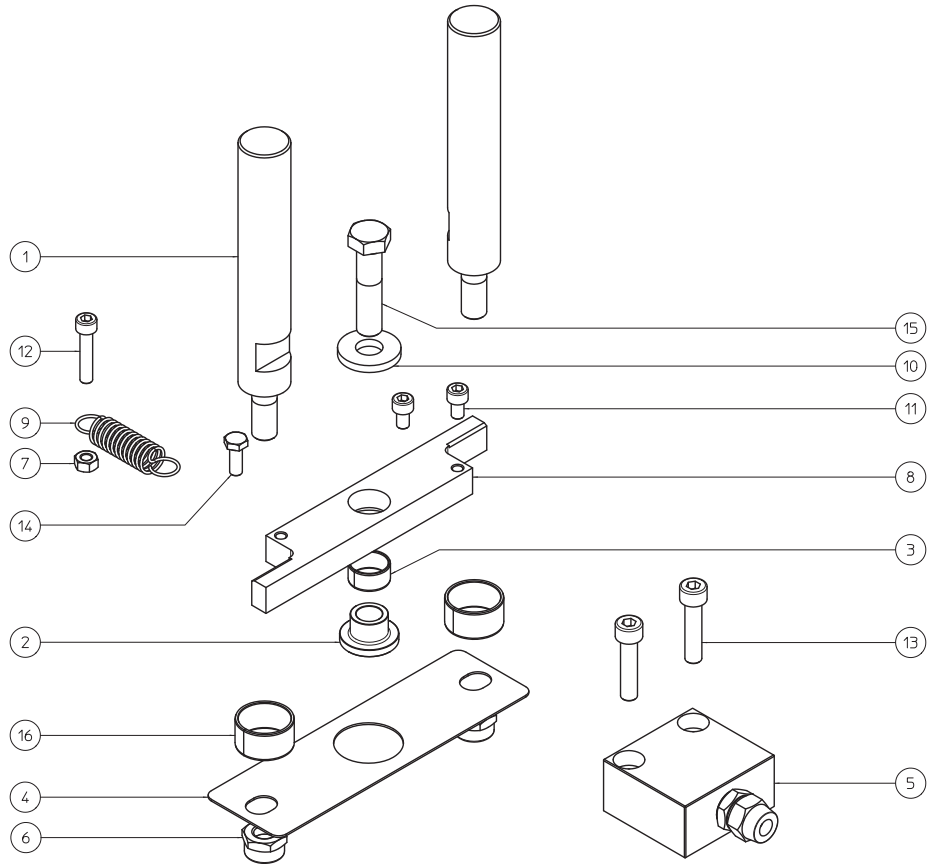

POSITION	QUANTITY	CODE	DESCRIPTION
1	2	14800006	ROD RELEASE
2	1	17910005	RELEASE LEVER LATCH INSERT
3	1	18061810	LATCH INSERT KU 18 10
4	1	20100078	SPACER FOR CYLINDER
5	1	23700013	HYDRAULIC CYLINDER C=20
6	2	30091201	NUT SELFLOCKING M12 ZINC.
7	1	30130601	NUT M6 ZINC.
8	1	42310026	CUTTING RELEASE LEVER
9	1	44830032	TRACTION SPRING T32010
10	1	59091230	WASHER D.12X30 SP. 4 ZINC.
11	2	69160610	SCREW TCEI M6X10 ZINC.
12	1	69160630	SCREW TCEI M6X30 ZINC.
13	2	69160835	SCREW TCEI M8X35 ZINC.
14	1	69200616	SCREW TE M6X16 ZINC.
15	1	69201250	SCREW TE M12X50 ZINC.
16	2	18062515	LATCH INSERT KF 25 15

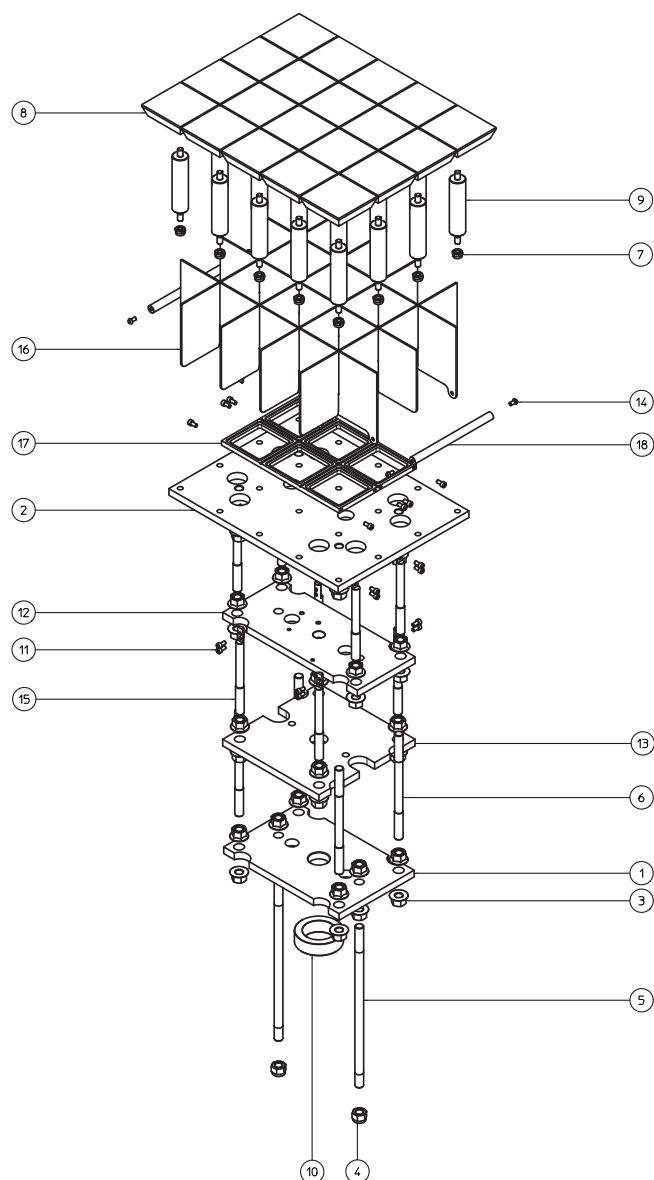

POSITION	QUANTITY	CODE	DESCRIPTION
1	1	49420122	PRESS SUPPORT GUIDE ROD PLATE
2	1	49420119	PRESS SUPPORT PLATE
3	32	30191601	NUT M16 ZINC.
4	2	30081601	SELFLOCKING NUT M16 ZINC.
5	2	65810012	FIXED LIMIT ROD
6	4	65810011	PRESS SUPPORT PLATE GUIDE RODS
7	20	30091001	SELFLOCKING NUT M10 ZINC.
8	20	52600030	PRESS PLATES
9	20	62000005	PRESS PLATE SUPPORT
10	1	30860007	SPACER FOR CYLINDER
11	20	69280612	SCREW TCEI M6X12 INOX
12	1	49420120	KNIFE SUPPORT PLATE
13	1	49420121	KNIFE SUPPORT PLATE
14	4	69290612	SCREW TCBEI M6X12 INOX
15	8	65810010	CUTTING KNIFE SUPPORT SHAFTS
16	1	60040143	KNIFE
17	1	49420130	KNIFE SUPPORT PLATE
18	2	14800014	ROD

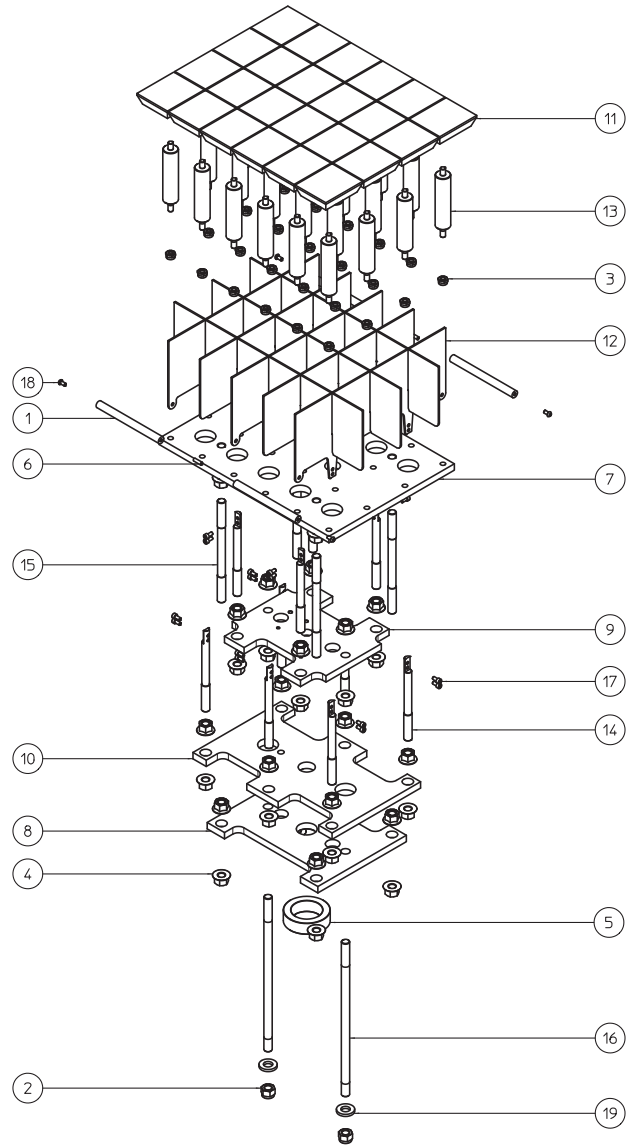

POSITION	QUANTITY	CODE	DESCRIPTION
1	4	14800015	ROD
2	2	30081601	SELFLOCKING NUT M16 ZINC.
3	24	30091001	SELFLOCKING NUT M10 ZINC.
4	36	30191601	NUT M16 ZINC.
5	1	30860007	SPACER FOR CYLINDER
6	2	37060831	SCREW STEI M6X20 INOX
7	1	49420165	PRESS SUPPORT PLATE
8	1	49420166	PRESS SUPPORT PLATE
9	1	49420167	KNIFE SUPPORT PLATE
10	1	49420168	KNIFE SUPPORT PLATE
11	24	52600036	PRESS PLATES
12	1	60040172	KNIFE
13	24	62000005	PRESS PLATE SUPPORT
14	10	65810010	CUTTING KNIFE SUPPORT SHAFTS
15	4	65810011	PRESS SUPPORT PLATE GUIDE RODS
16	2	65810012	FIXED LIMIT ROD
17	20	69280612	SCREW TCEI M6X12 INOX
18	4	69290612	SCREW TCBEI M6X12 INOX
19	2	59091635	WASHER D.16X35 SP. 5 ZINC.

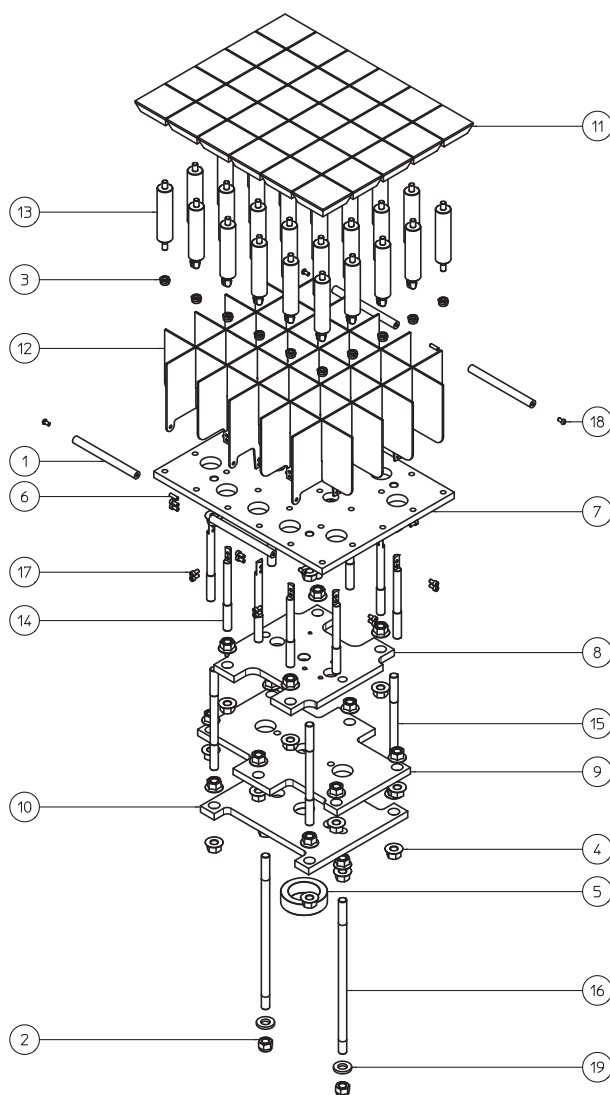

POSITION	QUANTITY	CODE	DESCRIPTION
1	4	14800015	ROD
2	2	30081601	SELFLOCKING NUT M16 ZINC.
3	30	30091001	SELFLOCKING NUT M10 ZINC.
4	36	30191601	NUT M16 ZINC.
5	1	30860007	SPACER FOR CYLINDER
6	2	37060831	SCREW STEI M6X20 INOX
7	1	49420138	PRESS SUPPORT PLATE
8	1	49420139	KNIFE SUPPORT PLATE
9	1	49420140	KNIFE SUPPORT PLATE
10	1	49420141	PRESS SUPPORT PLATE
11	30	52600035	PRESS PLATES
12	1	60040151	KNIFE
13	30	62000005	PRESS PLATE SUPPORT
14	10	65810010	CUTTING KNIFE SUPPORT SHAFTS
15	4	65810011	PRESS SUPPORT PLATE GUIDE RODS
16	2	65810012	FIXED LIMIT ROD
17	20	69280612	SCREW TCEI M6X12 INOX
18	4	69290612	SCREW TCBEI M6X12 INOX
19	2	59091635	WASHER D.16X35 SP. 5 ZINC.



**ROUND BASIN GROUP COD. VS000008**

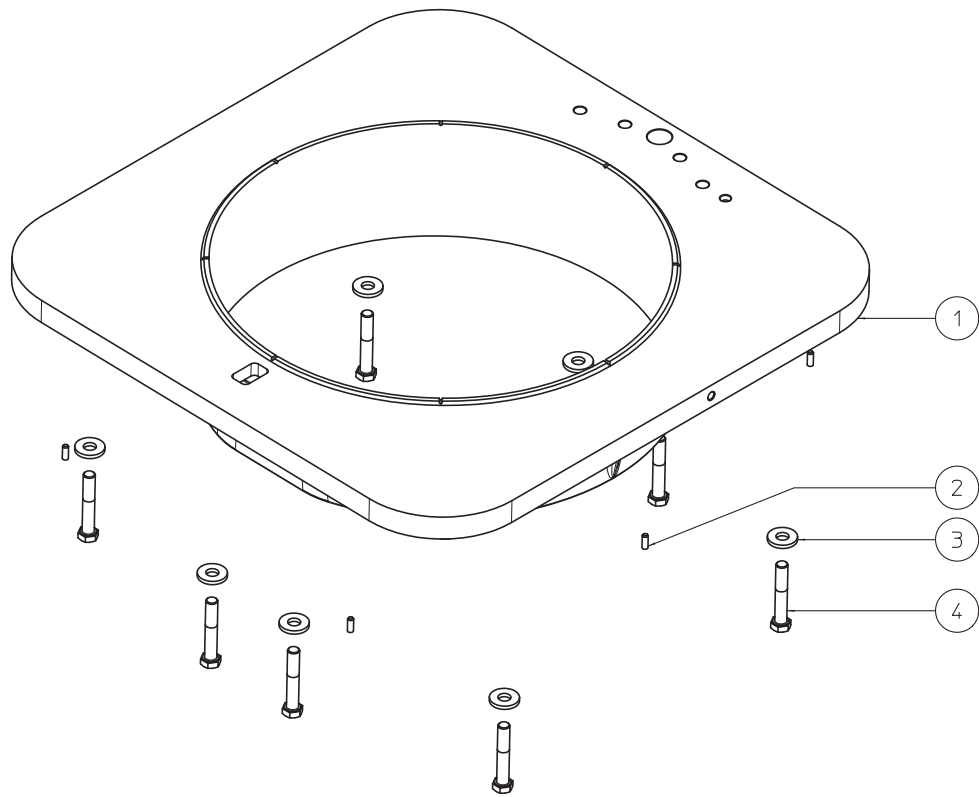

POSITION	QUANTITY	CODE	DESCRIPTION
1	1	35150007	ROUND BASIN
2	6	37040616	SCREW M06X16
3	8	59091230	WASHER D.12X30 SP. 4 ZINC.
4	8	69201270	SCREW M12X70 ZINC.



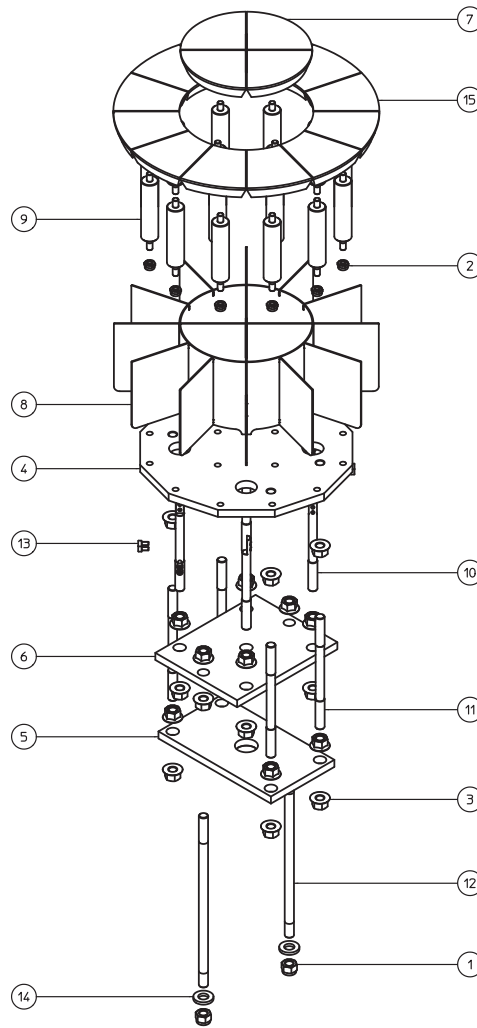

POSITION	QUANTITY	CODE	DESCRIPTION
1	2	30081601	NUT M10 ZINC.
2	16	30091001	NUT M16 ZINC.
3	24	30191601	PRESS SUPPORT PLATE
4	1	49420156	PRESS SUPPORT GUIDE ROD PLATE
5	1	49420157	KNIFE SUPPORT PLATE
6	1	49420158	INSIDE PRESS PLATES
7	4	52600043	KNIFE
8	1	60040163	PRESS PLATE SUPPORT
9	16	62000005	CUTTING KNIFE SUPPORT SHAFTS
10	4	65810010	PRESS SUPPORT PLATE GUIDE RODS
11	4	65810011	FIXED LIMIT ROD
12	2	65810012	SCREW TCEI M6X12 INOX
13	8	69280612	WASHER D.16X35 SP. 45 ZINC.
14	2	59091635	OUTSIDE PRESS PLATES
15	12	52600044	BALANCE CHAIN

20 DIVISIONS KNIFE GROUP **COD. TG000016**

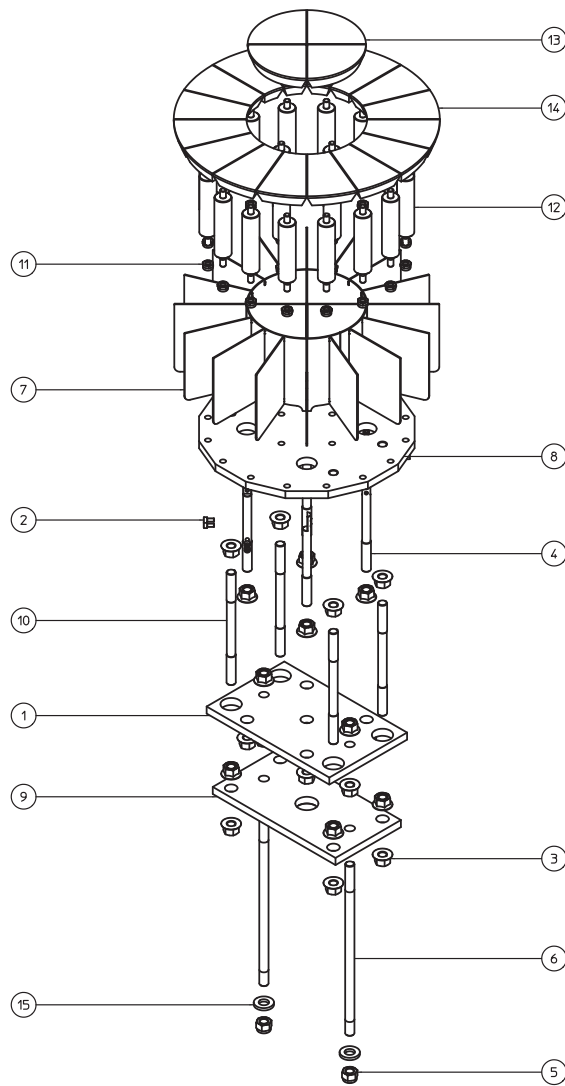

POSITION	QUANTITY	CODE	DESCRIPTION
1	1	49420117	KNIFE SUPPORT PLATE
2	8	69280612	SCREW TCEI M6X12 INOX
3	24	30191601	NUT M16 ZINC.
4	4	65810010	CUTTING KNIFE SUPPORT SHAFTS
5	2	30081601	SELFLOCKING NUT M16 ZINC.
6	2	65810012	FIXED LIMIT ROD
7	1	60040142	KNIFE
8	1	49420116	PRESS SUPPORT PLATE
9	1	49420118	PRESS SUPPORT GUIDE ROD PLATE
10	4	65810011	PRESS SUPPORT PLATE GUIDE RODS
11	20	30091001	NUT M10 ZINC.
12	20	62000005	PRESS PLATE SUPPORT
13	4	52600032	INSIDE PRESS PLATES
14	16	52600033	OUTSIDE PRESS PLATES
15	2	59091635	WASHER D.16X35 SP. 45 ZINC.

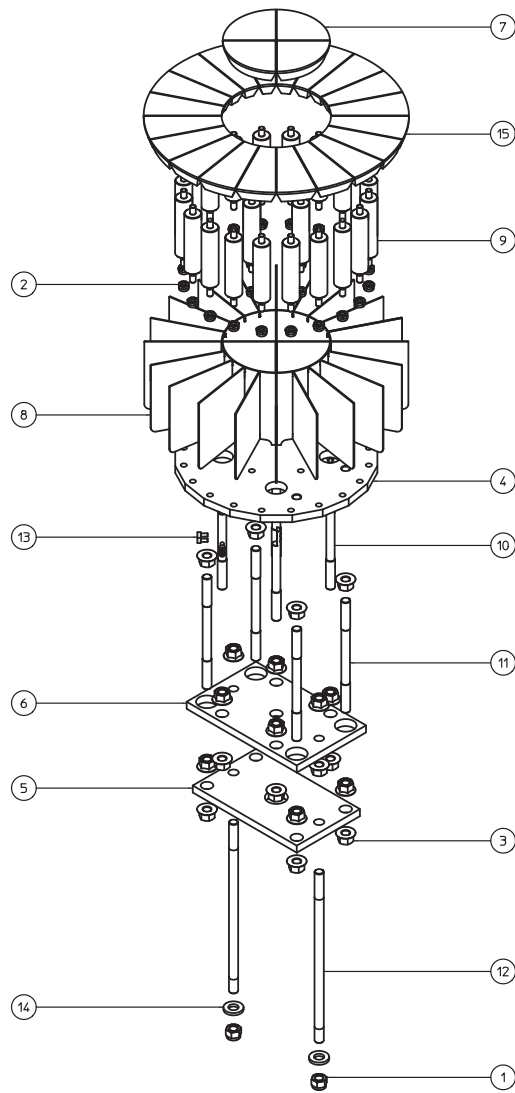

POSITION	QUANTITY	CODE	DESCRIPTION
1	2	30081601	SELFLOCKING NUT M16 ZINC.
2	24	30091001	NUT M10 ZINC.
3	24	30191601	NUT M16 ZINC.
4	1	49420146	PRESS SUPPORT PLATE
5	1	49420147	PRESS SUPPORT GUIDE ROD PLATE
6	1	49420148	KNIFE SUPPORT PLATE
7	4	52600038	INSIDE PRESS PLATES
8	1	60040158	KNIFE
9	24	62000005	PRESS PLATE SUPPORT
10	4	65810010	CUTTING KNIFE SUPPORT SHAFTS
11	4	65810011	PRESS SUPPORT PLATE GUIDE RODS
12	2	65810012	FIXED LIMIT ROD
13	8	69280612	SCREW TCEI M6X12 INOX
14	2	59091635	WASHER D.16X35 SP. 45 ZINC.
15	20	52600039	OUTSIDE PRESS PLATES

**EXAGONAL BASIN 37/57 GROUP COD. VS000009**

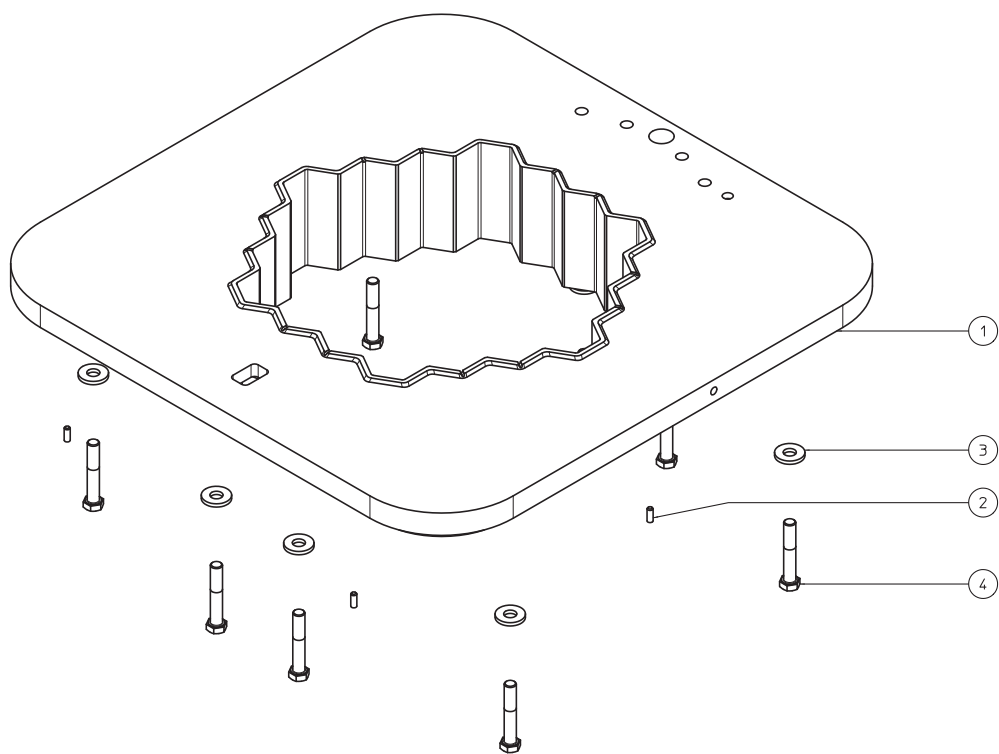

POSITION	QUANTITY	CODE	DESCRIPTION
1	1	35150010	EXAGONAL BASIN
2	6	37040616	SCREW M06X16
3	8	59091230	WASHER D.12X30 SP. 4 ZINC.
4	8	69201270	SCREW M12X70 ZINC.

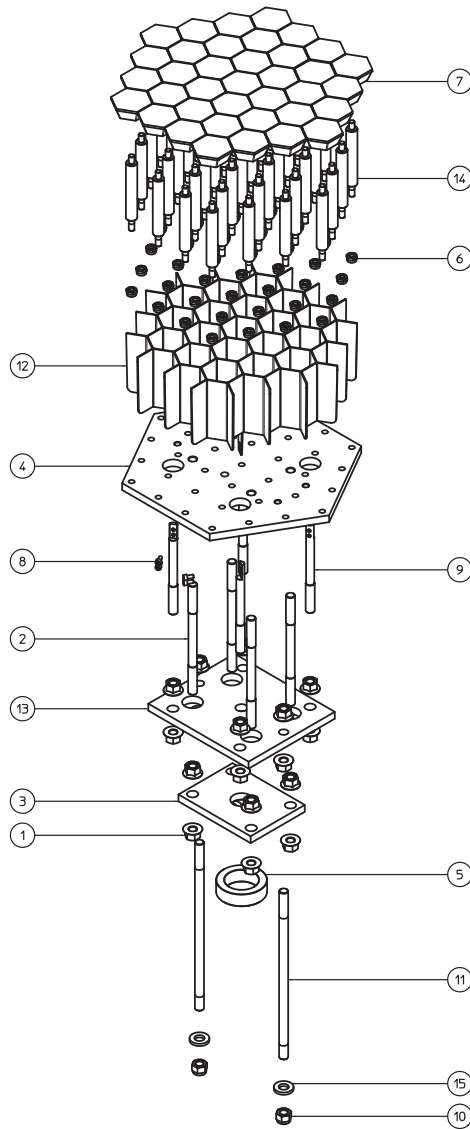

POSITION	QUANTITY	CODE	DESCRIPTION
1	2	30081601	SELFLOCKING NUT M16 ZINC.
2	37	30091001	NUT M10 ZINC.
3	24	30191601	NUT M16 ZINC.
4	1	30860007	CYLINDER RACING SPACER
5	1	49420143	PRESS SUPPORT PLATE
6	1	49420144	KNIFE SUPPORT PLATE
7	1	49420145	PRESS SUPPORT GUIDE ROD PLATE
8	37	52600037	PRESS PLATES AC57
9	1	60040155	KNIFE
10	37	62000006	PRESS PLATE SUPPORT
11	4	65810010	CUTTING KNIFE SUPPORT SHAFTS
12	2	65810012	FIXED LIMIT ROD
13	8	69280612	SCREW TCEI M6X12 INOX
14	4	65810011	PRESS SUPPORT PLATE GUIDE RODS
15	2	59091635	WASHER D.16X35 SP. 45 ZINC.



EXAGONAL BASIN 37/65 GROUP **COD. VS000011**

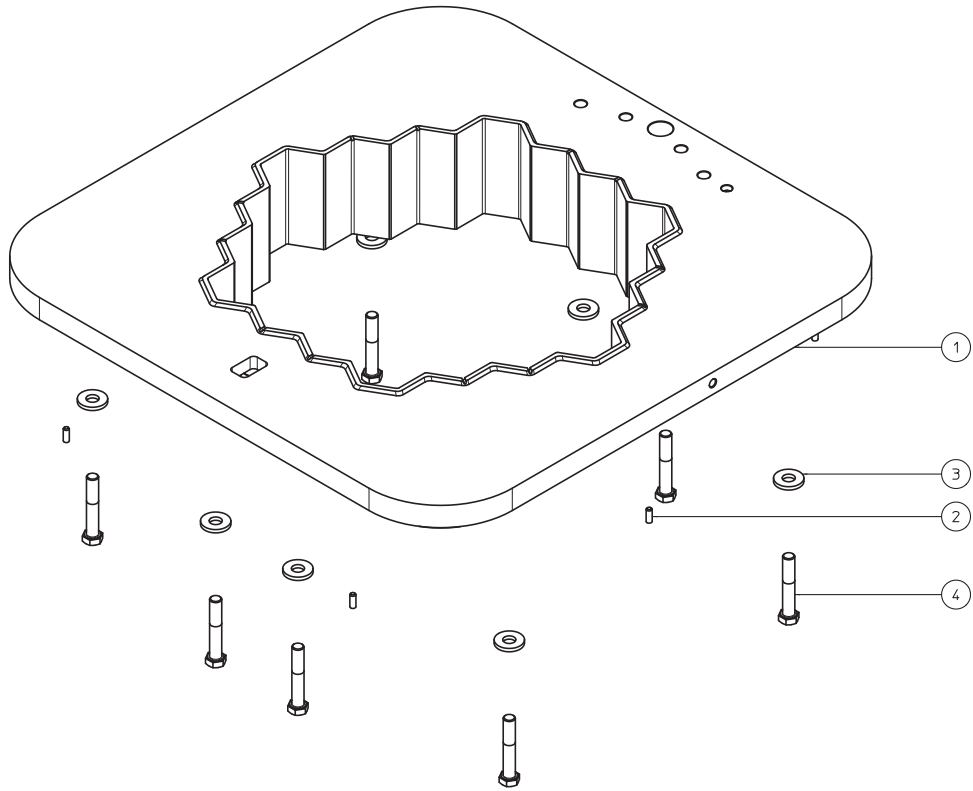

POSITION	QUANTITY	CODE	DESCRIPTION
1	1	35150009	EXAGONAL BASIN
2	6	37040616	CREW M06X16
3	8	59091230	WASHER D.12X30 SP. 4 ZINC.
4	8	69201270	SCREW M12X70 ZINC.

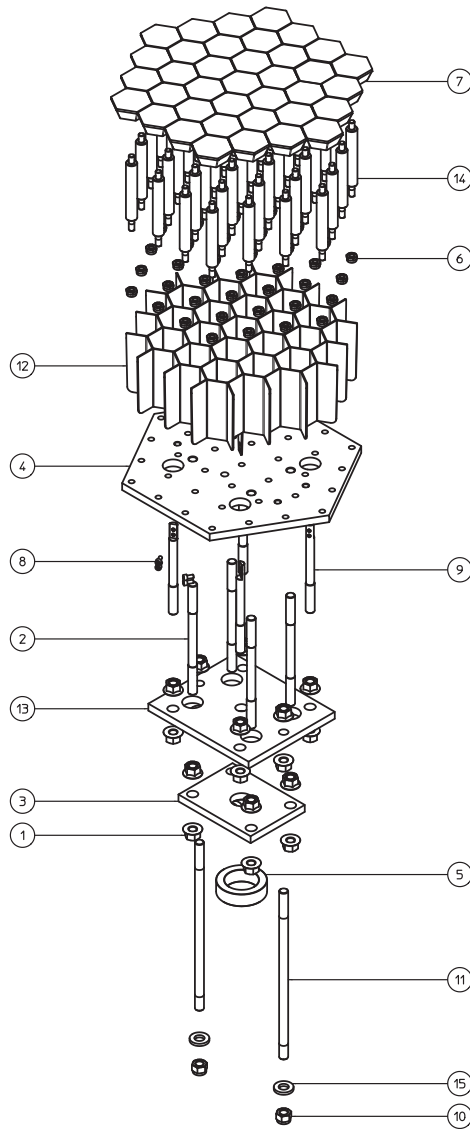

POSITION	QUANTITY	CODE	DESCRIPTION
1	24	30191601	NUT M16 ZINC.
2	4	65810011	PRESS SUPPORT PLATE GUIDE RODS
3	1	49420115	PRESS SUPPORT GUIDE ROD PLATE
4	1	49420113	PRESS SUPPORT PLATE
5	1	30860007	CYLINDER RACING SPACER
6	37	30091001	NUT M10 ZINC.
7	37	52600031	PRESS PLATES AC65
8	8	69280612	SCREW TCEI M6X12 INOX
9	4	65810010	CUTTING KNIFE SUPPORT SHAFTS
10	2	30081601	SELFLOCKING NUT M16 ZINC.
11	2	65810012	FIXED LIMIT ROD
12	1	60040141	KNIFE
13	1	49420114	KNIFE SUPPORT PLATE
14	37	62000006	PRESS PLATE SUPPORT
15	2	59091635	WASHER D.16X35 SP. 45 ZINC.

**EXAGONAL BASIN 85 GROUP COD. VS000010**

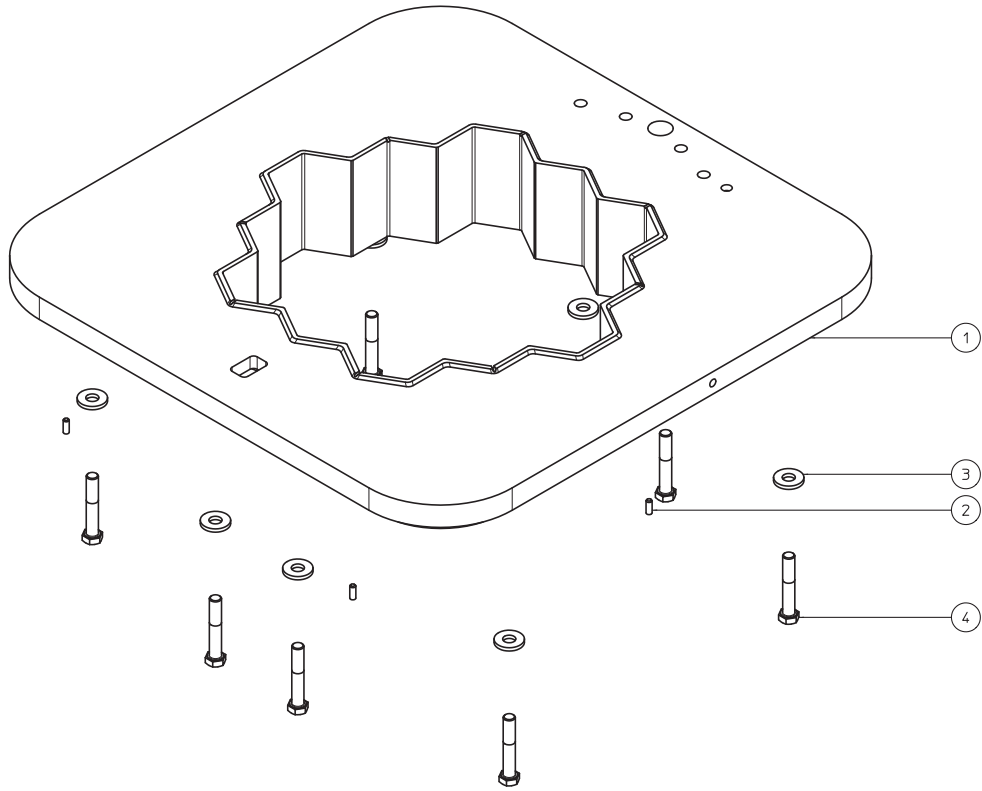

POSITION	QUANTITY	CODE	DESCRIPTION
1	1	35150009	EXAGONAL BASIN
2	6	37040616	SCREW M06X16
3	8	59091230	WASHER D.12X30 SP. 4 ZINC.
4	8	69201270	SCREW M12X70 ZINC.



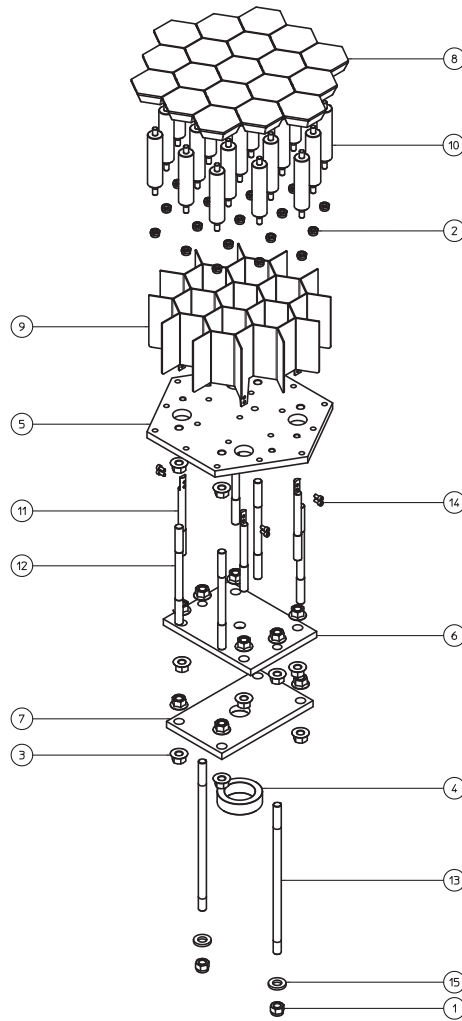

POSITION	QUANTITY	CODE	DESCRIPTION
1	2	30081601	SELFLOCKING NUT M16 ZINC.
2	19	30091001	NUT M10 ZINC.
3	24	30191601	NUT M16 ZINC.
4	1	30860007	CYLINDER RACING SPACER
5	1	49420149	PRESS SUPPORT PLATE
6	1	49420150	KNIFE SUPPORT PLATE
7	1	49420151	PRESS SUPPORT GUIDE ROD PLATE
8	19	52600040	PRESS PLATES AC85
9	1	60040159	KNIFE
10	19	62000005	PRESS PLATE SUPPORT
11	4	65810010	CUTTING KNIFE SUPPORT SHAFTS
12	4	65810011	PRESS SUPPORT PLATE GUIDE RODS
13	2	65810012	FIXED LIMIT ROD
14	8	69280612	SCREW TCEI M6X12 INOX
15	2	59091635	WASHER D.16X35 SP. 45 ZINC.



RECTANGULAR SMALL BASIN GROUP **COD. VS000012**

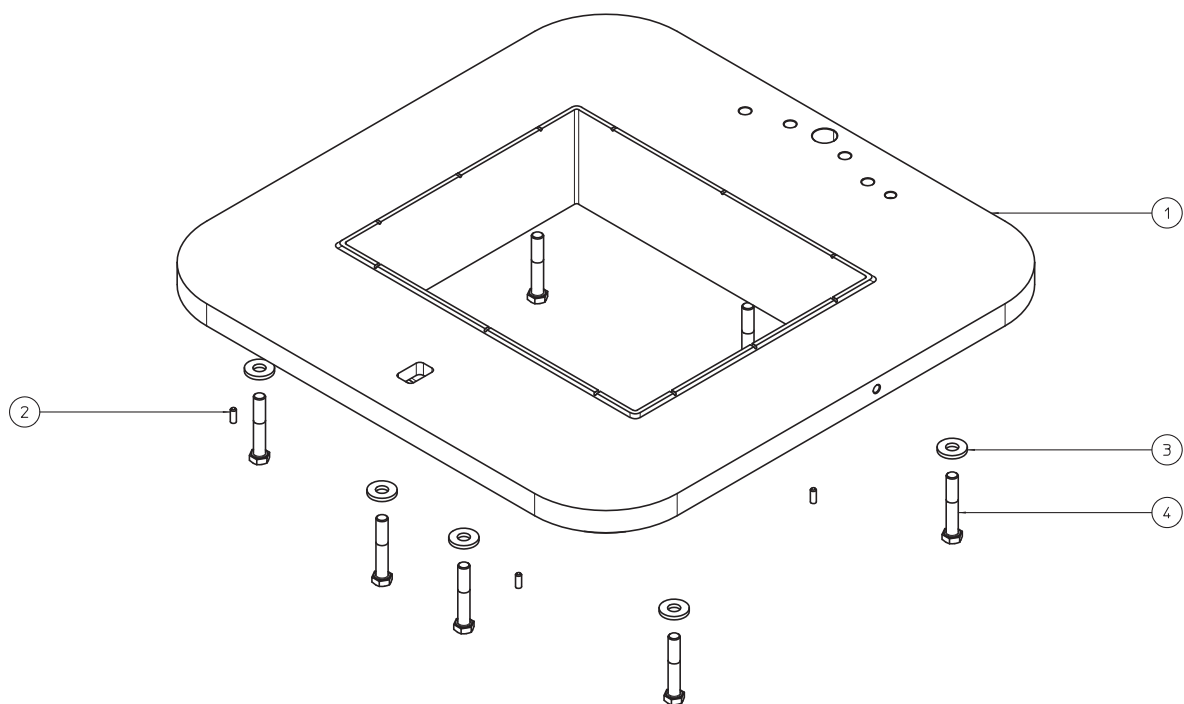

POSITION	QUANTITY	CODE	DESCRIPTION
1	1	35150006	RECTANGULAR SMALL BASIN
2	6	37040616	SCREW M06X16
3	8	59091230	WASHER D.12X30 SP. 4 ZINC.
4	8	69201270	SCREW M12X70 ZINC.

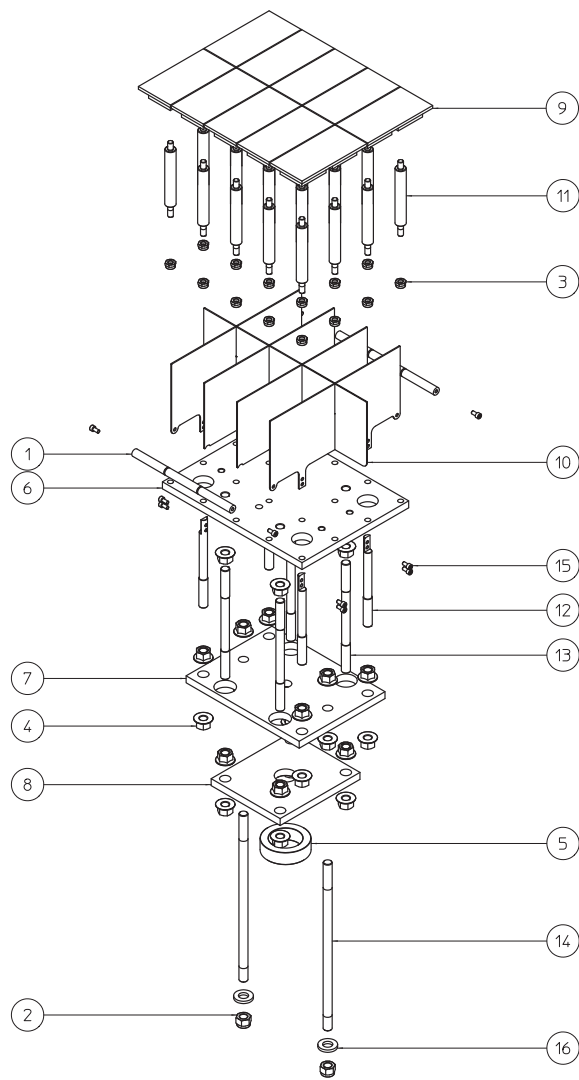

POSITION	QUANTITY	CODE	DESCRIPTION
1	2	14800017	ROD
2	2	30081601	SELFLOCKING NUT M16 ZINC.
3	20	30091001	NUT SELFLOCKING M10 ZINC.
4	24	30191601	NUT M16 ZINC.
5	1	30860007	CYLINDER RACING SPACER
6	1	49420159	PRESS SUPPORT PLATE
7	1	49420160	KNIFE SUPPORT PLATE
8	1	49420161	PRESS SUPPORT GUIDE ROD PLATE
9	10	52600021	PRESS PLATES
10	1	60040164	KNIFE
11	20	62000006	PRESS PLATE SUPPORT
12	4	65810010	CUTTING KNIFE SUPPORT SHAFTS
13	4	65810011	PRESS SUPPORT PLATE GUIDE RODS
14	2	65810012	FIXED LIMIT ROD
15	12	69280612	SCREW TCEI M6X12 INOX
16	2	59091635	WASHER D.16X35 SP. 5 ZINC.

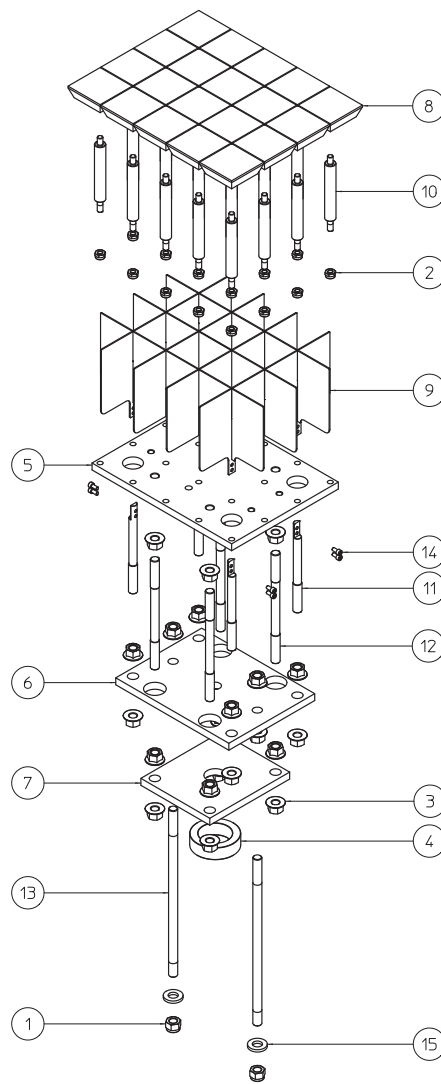

POSITION	QUANTITY	CODE	DESCRIPTION
1	2	30081601	NUT SELFLOCKING M10 ZINC.
2	20	30091001	NUT SELFLOCKING M10 ZINC.
3	24	30191601	NUT M16 ZINC.
4	1	30860007	CYLINDER RACING SPACER
5	1	49420159	PRESS SUPPORT PLATE
6	1	49420160	KNIFE SUPPORT PLATE
7	1	49420161	PRESS SUPPORT GUIDE ROD PLATE
8	20	52600004	PRESS PLATES
9	1	60040165	KNIFE
10	20	62000006	PRESS PLATE SUPPORT
11	4	65810010	CUTTING KNIFE SUPPORT SHAFTS
12	4	65810011	PRESS SUPPORT PLATE GUIDE RODS
13	2	65810012	FIXED LIMIT ROD
14	8	69280612	SCREW TCEI M6X12 INOX
15	2	59091635	WASHER D.16X35 SP. 5 ZINC.



## HYDRAULIC SYSTEM GROUP

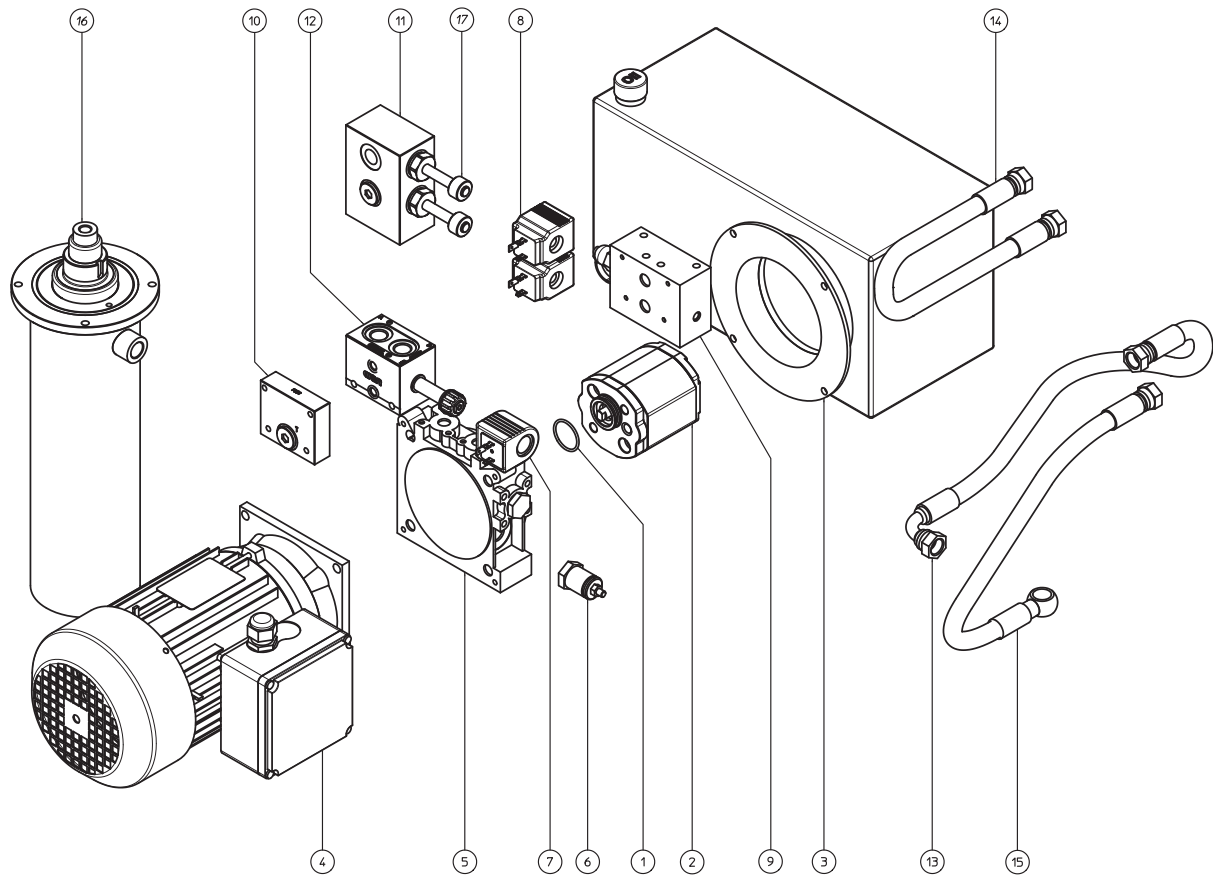

POSITION	QUANTITY	CODE	DESCRIPTION
1	1	38693106	OR SEAL 3106
2	1	50970002	PUMP MOD. K1P D 15 G P199
2	1	50970003	PUMP MOD. "T" PHC 1-6,0 X MC (MOTOR MONOPHASE)
3	1	60060004	OIL TANK
4	1	45200002	MOTOR THREE PHASES 230-400/3/50-60 STANDARD
4	1	45220002	MOTOR THREE PHASES UL 230/3/60
4	1	45120002	MOTOR MONOPHASE UL 230/1/60
4	1	45150002	MOTOR MONOPHASE UL 110/1/60
5	1	28320006	HYDRAULIC BODY
6	1	30900001	VALVLE
7	1	17500001	COIL A0924DDC STANDARD
7	1	17500004	COIL A0924VDC-27W M UL
8	2	17500003	COIL 24VDC - 18W STANDARD
8	2	17500005	COIL 24VDC-EC360 22W UL
9	1	28320002	INTERFACE BLOCK
10	1	28320004	BLOCK FU31
11	1	28330001	INTERFACE BLOCK
12	1	31770009	PARALLEL COMPONIBLE DISTRIBUTOR
13	1	66950006	PIPE R1T 3/8" FD+F90
14	1	66950008	PIPE R1T 3/8" FD+FD
15	1	66950009	PIPE R1T 3/8" OC+FD
16	1	23700002	HYDRAULIC CYLINDER
17	1	19800002	CARTRIDGE DOUBLE SEAL

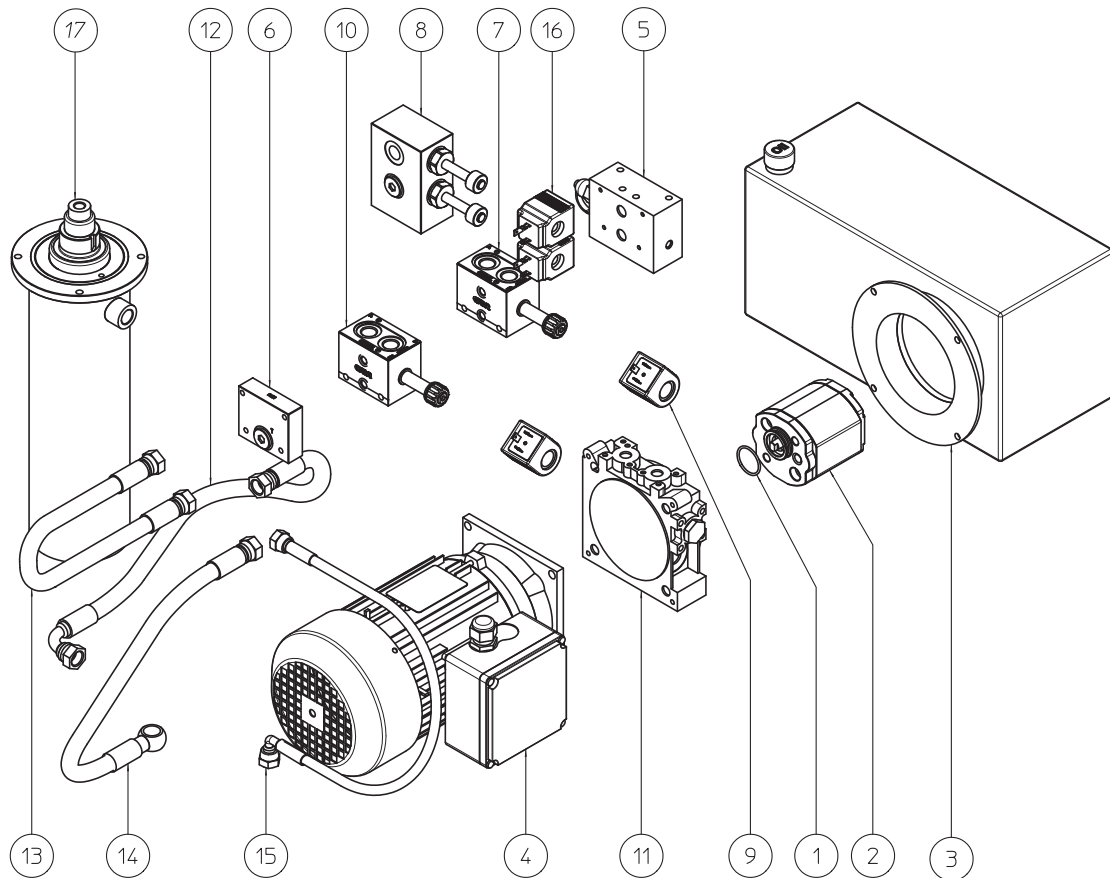

POSITION	QUANTITY	CODE	DESCRIPTION
1	1	38693106	OR SEAL 3106
2	1	50970002	PUMP MOD. K1P D 15 G P199
2	1	50970003	PUMP MOD. "T" PHC 1-6,0 X MC (MOTOR MONOPHASE)
3	1	60060004	OIL TANK
4	1	45200002	MOTOR THREE PHASES 230-400/3/50-60 STANDARD
4	1	45220002	MOTOR THREE PHASES UL 230/3/60
4	1	45120002	MOTOR MONOPHASE UL 230/1/60
4	1	45150002	MOTOR MONOPHASE UL 110/1/60
5	1	28320002	INTERFACE BLOCK
6	1	28320004	BLOCK FU31
7	1	31770009	PARALLEL COMPONIBLE DISTRIBUTOR
8	1	28330001	INTERFACE BLOCK
9	2	17500001	COIL A0924DDC STANDARD
9	2	17500004	COIL A0924VDC-27W M UL
10	1	31770001	PARALLEL COMPONIBLE DISTRIBUTOR 3/8"
11	1	28320006	HYDRAULIC BODY
12	1	66950006	PIPE R1T 3/8" FD+F90
13	1	66950008	PIPE R1T 3/8" FD+FD
14	1	66950009	PIPE R1T 3/8" OC+FD
15	1	66950012	PIPE R7 3/16" FD 1/4+F90 1/4
16	2	17500003	COIL 24VDC - 18W STANDARD
16	2	17500005	COIL 24VDC-EC360 22W UL
17	1	23700002	HYDRAULIC CYLINDER

**ELECTRICAL GROUP**

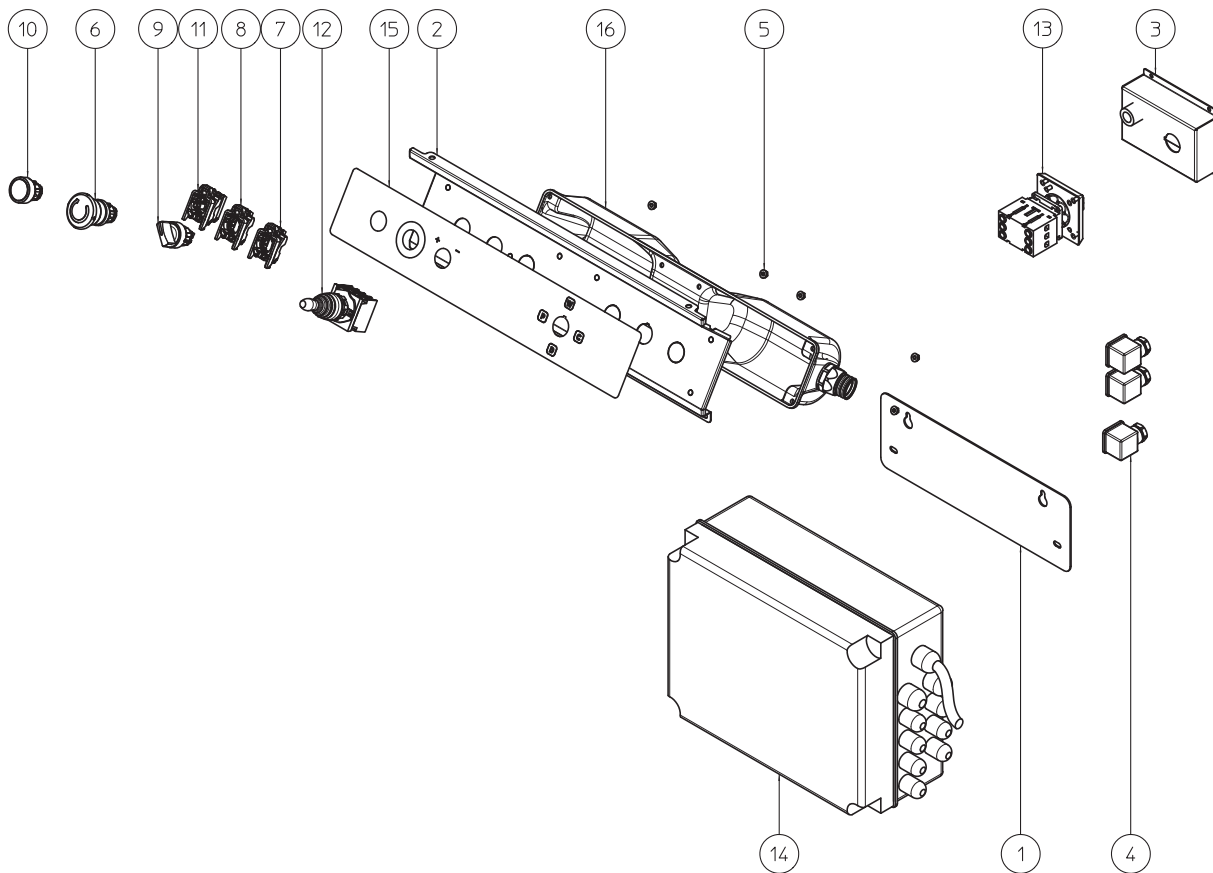

POSITION	QUANTITY	CODE	DESCRIPTION
1	1	20100417	FIXING PLATE
2	1	20120298	CONTROL PANEL PLATE
3	1	20120324	POWER SUPPLY COVER
4	3	25300001	CONNECTOR VDR-220V CNT532 PG09 NE
5	6	30190401	NUT M4 ZINC.
6	1	53800001	EMERGENCY STOP BUTTON
7	1	53800009	SELECTOR CONTACTS
8	1	53800014	EMERGENCY STOP BUTTON SUPPORT
9	1	53800015	SWITCH
10	1	53800022	WHITE LIGHT
11	1	53800023	LID LIGHT SUPPORT
12	1	53800032	4 POSITIONS JOYSTICK
13	1	53800033	MAIN SWITCH
14	1	53800051	PLASTIC ELECTRICAL BOX (STANDARD)
14	1	53800045	PAINTED STEEL ELECTRICAL BOX (UL)
15	1	60850003	SERIGRAPHY
15	1	60850001	SERIGRAPHY DOUBLE CUT
16	1	65610001	CONTROL PANEL REAR COVER



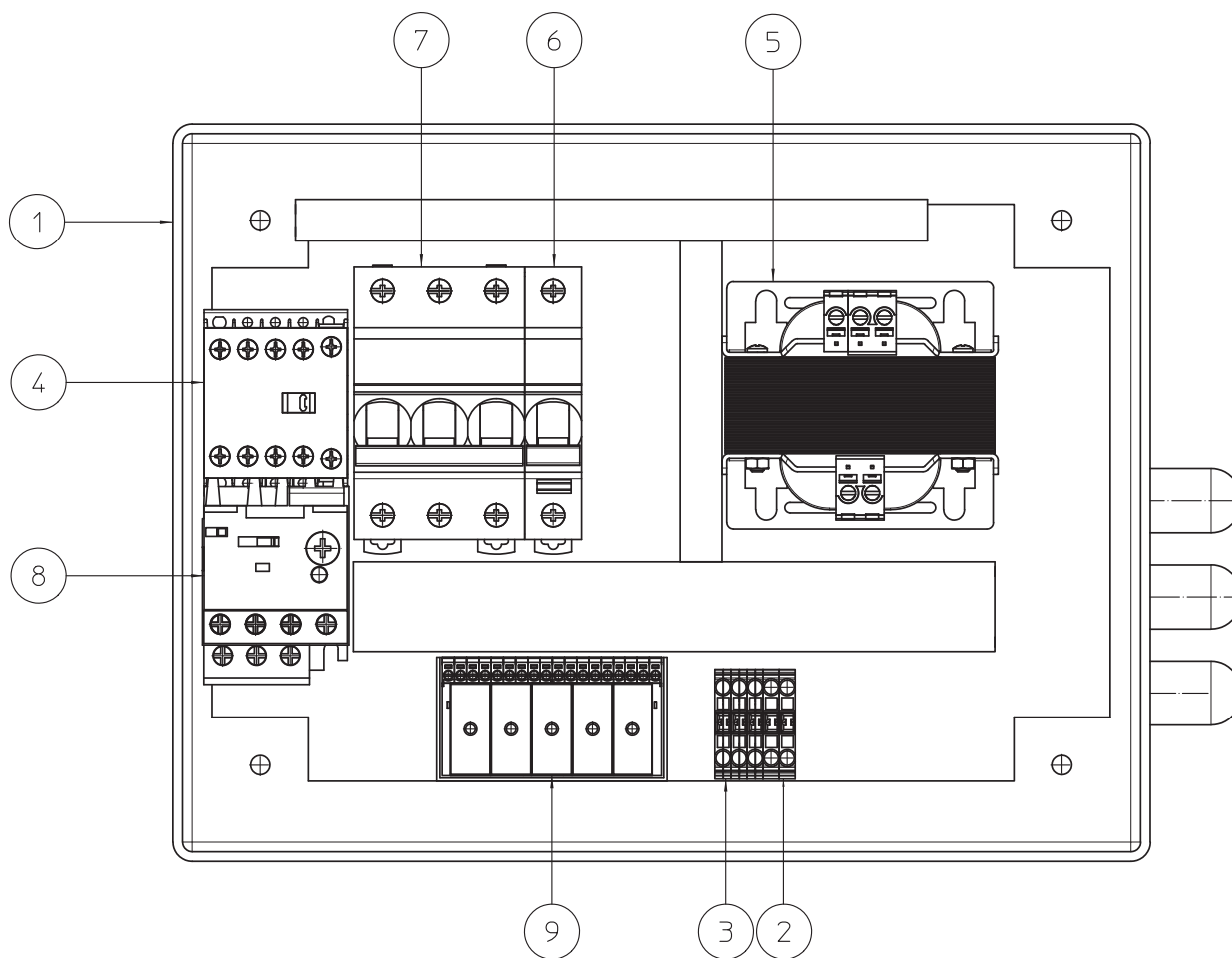

POSITION	QUANTITY	CODE	DESCRIPTION
1	1	53800045	PAINTED STEEL ELECTRICAL BOX (UL)
2	4	53800057	CLAMPS 2,5 MMQ
3	3	53800058	GROUD CLAMPS 2,5 MMQ
4	1	65050002	CONTACTOR
5	1	66000013	TRANSFORMER 230/3/60 - 230/1/60 - 110/1/60 UL
6	1	66000017	THERMAL OVERLOAD 10/14 A - 110 V 1 PH
6	1	66000018	THERMAL OVERLOAD 5,5/8 A - 230 V 1 PH
6	1	66000005	THERMAL OVERLOAD 3,7/5,5 A - 230 V 3 PH
7	1	66000015	CIRCUIT BREAKER UNIP. C4
8	1	66000016	CIRCUIT BREAKER TRIP. C16
9	1	66000019	PC BOARD WITH RELAY'

**ELECTRICAL BOX STANDARD**

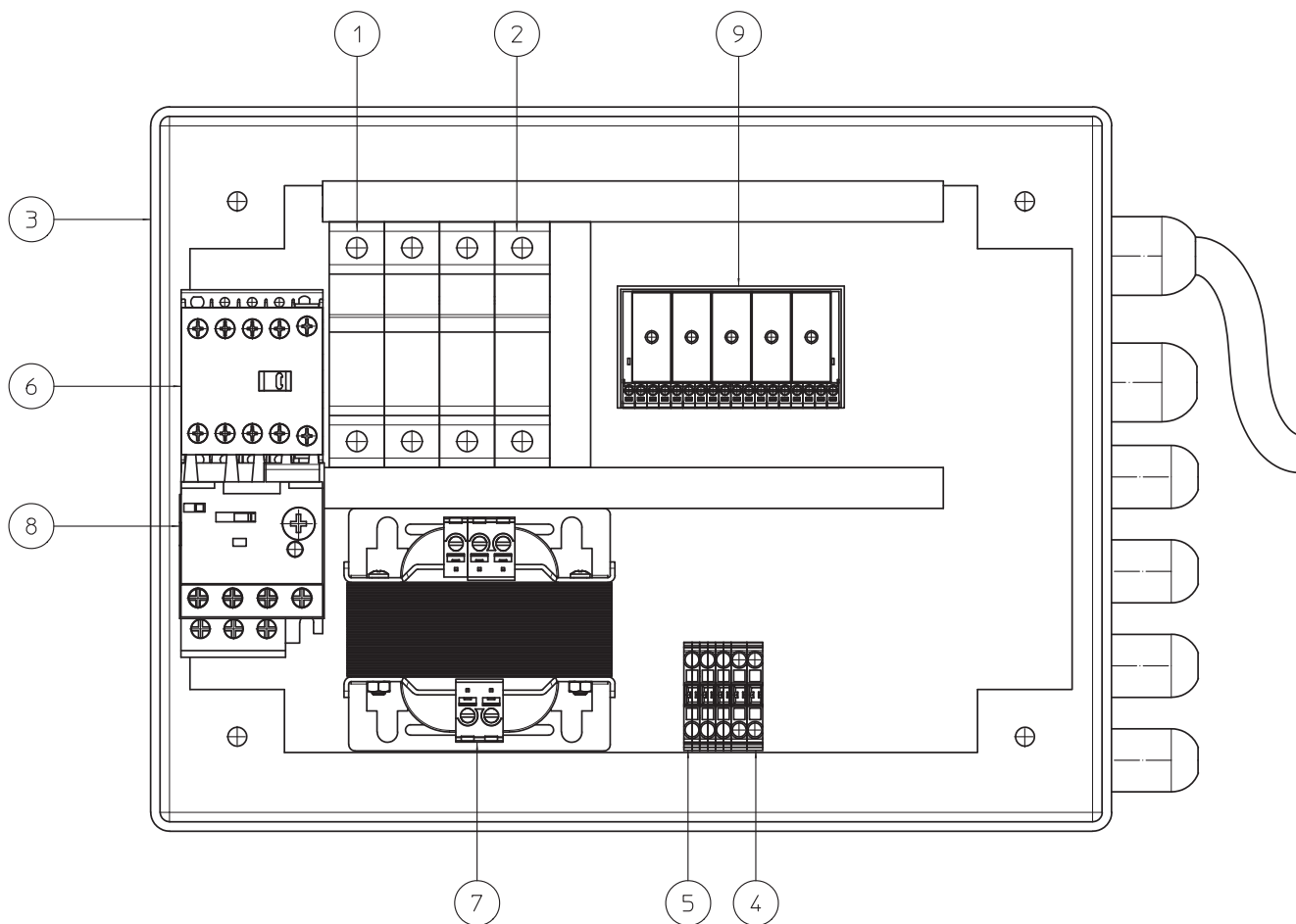

POSITION	QUANTITY	CODE	DESCRIPTION
1	1	49070001	FUSE HOLDER THREE POLE RM32A 10X38
2	1	49070002	FUSE HOLDER SINGLE POLE RM32A 10X38
3	1	53800051	PLASTIC ELECTRICAL BOX
4	2	53800057	CLAMPS 2,5 MMQ
5	3	53800058	GROUD CLAMPS 2,5 MMQ
6	1	65050002	CONTACTOR
7	1	66000001	TRANSFORMER 230/3/50-60 - 400/3/50-60 CE
8	1	66000004	THERMAL OVERLOAD 1,8/2,6 A - 400 V 3 PH
8	1	66000005	THERMAL OVERLOAD 3,7/5,5 A - 230 V 3 PH
9	1	66000019	PC BOARD WITH RELAY'





All machines are in conformity with EC regulations and are manufactured in Italy.